

# WOOSUNG VACUUMPUMP

<http://www.vacuumkorea.com>

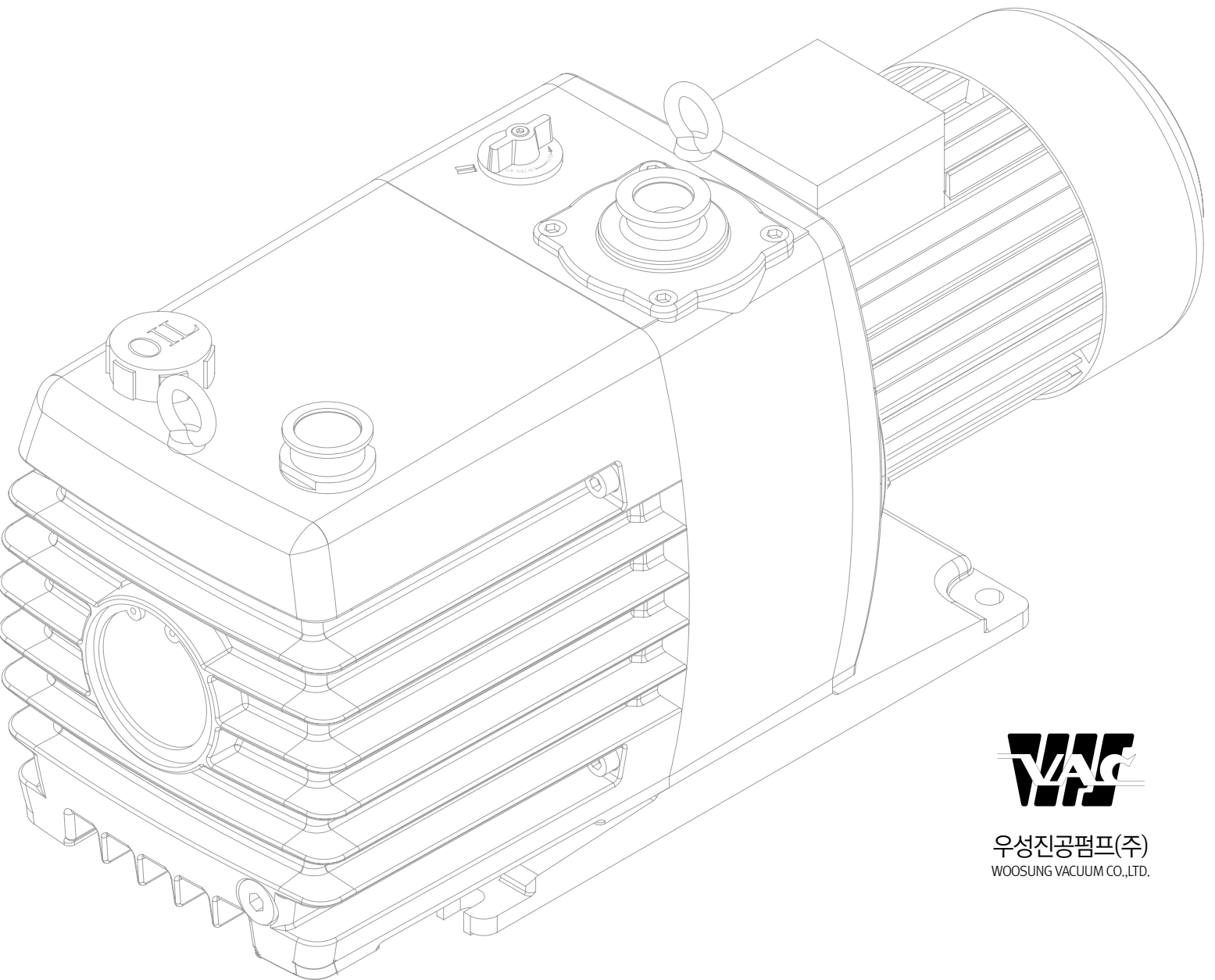

우성진공펌프(주)  
WOOSUNG VACUUM CO., LTD.

# WOOSUNG VACUUMPUMP

우성은 고객만족이라는 품질방침과 제품 결함의 ZERO화라는 품질 목표를 실현하기 위하여 의식 개혁을 기반으로 하는 품질개선활동을 통해 전사원이 참여하여 회사의 품질시스템 실행 및 유지를 위해 최선을 다하고 있습니다.

In order for customer's satisfaction, we should always be able to guarantee best products.

To be accomplished ZERO DEFECT on our products, all staff participate in Quality Improvement campaign and do their best to run in Quality Control System.

To satisfy our customers, Woosung improves its productivity, standardize products by using equipments with latest technologies.

It comes cost savings, competitive prices and high quality products to meet our marketing strategy.

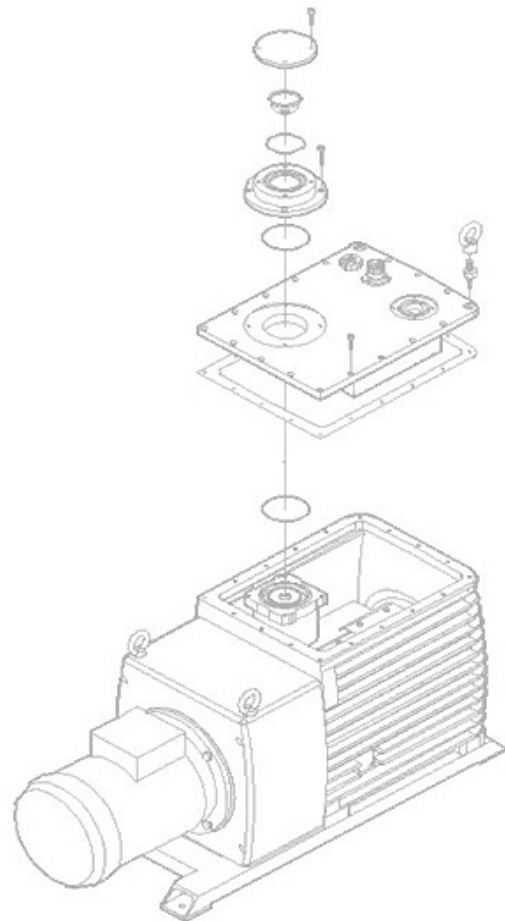









---

## 회사소개

저희 우성진공은 진공펌프 전문생산업체로서 1976년 진공관련 부품생산을 시작으로 지금까지 진공펌프 단일품목의 집중적인 연구와 품질향상에 헌신의 노력을 기울여 왔으며 전 세계로 뻗어 나가는 명실 상부한 대한민국 제일의 펌프 제조회사입니다.

주요 생산품목으로는 오일로타리 베인진공펌프, 부스터진공펌프, 드라이진공펌프 등 7종 34품목의 진공펌프를 생산하고 있으며, 이들 제품에 대한 기술과 품질을 인정받아 한국, 미국 등으로부터 55가지의 특허권을 비롯하여, 국제인증 기관으로부터 ISO9001과 ISO14001, UL, CE, TI 인증을 취득하고 있습니다.

생산규모로는 대지 17,534㎡ 건축면적 3,490㎡의 제주1공장과, 대지 8,500㎡, 건평 3,500㎡의 인천 제 2공장이 있고, 주요 제품인 MVP외 7종 34품목의 펌프를 연간 약 10,000대의 펌프 생산이 가능한 시설을 갖추고 있습니다.

작지만 강한 기업을 표방하고 있는 우성은 21세기 세계일류의 기업으로 거듭나기 위하여 외국로의 투자 진출 등 시장 다각화를 적극 모색하고 있으며, 세계 제일의 펌프 제조 및 모든 진공산업 시스템을 지원하기 위하여 최선의 노력을 다하고 있습니다.

---

## Company Introduction

Woosung Vacuum Co., Ltd is a professional manufacturer of vacuum pumps and the company started manufacturing of the products related with vacuum since 1976. Since that time, the company has made every effort to manufacturing of the products related with vacuum since that time, the company has made every effort to manufacture the single item of the best quality vacuum product and contributed ourselves to the improvement of the quality of the products. Woosung Vacuum Co. Ltd. is one of the most vacuum pump manufacturers in Korea.

Main products of the company are 7 kinds and 34 items of Oil Rotary Vane Vacuum Pumps, Booster Vacuum Pumps, Dry vacuum pumps, etc. As the technology and quality of the company's goods have been acknowledged by the relevant circle, the company has already acquired more than 55 organization rights from Korea, China and U.S.A. etc and also obtained the international licenses of ISO9001, ISO 14001, CE, TI and UL from the relevant international organizations.

The company has the land of 17,534㎡ and building 3,490㎡ the 1st factory and head office in Jeju and 8,500㎡ and building area of 3,500㎡ in the 2nd factory in Incheon with the capacity to produce 10,000 sets of MVP vacuum pumps and 7 kinds and 34 items. In spite of the small size of the company, we are promoting powerful industry. Therefore Woosung is progressively seeking for advancing into multiple international markets so that the company can be reborn as the first class enterprise in 21st century. We will make more effort in the future with the faith that we should play an important role not only basic industry but also in the ultra modern industry in the relevant field. And as our best manufacturing of products and systems will play role basement of all industry, Woosung Vacuum.Co.Ltd do our best effort.

Thank you.



## 연혁

- 1976. 11 ● 회사설립
- 1978. 02 ● 오일로터리 진공펌프 개발
- 1986. 11 ● 우수국산기계 개발 우수업체 상공부 장관상 수상
- 1988. 04 ● 현물출자에 의한 법인전환
- 1990. 06 ● 유회전식 진공펌프 개발
  - 베인 펌프 2단형 : WSPV9018, WSPV9030, WSPV9060
  - 피스톤형 : WSSR-1.5K, 2.5K, 4.5K, 7.5K, WSDR-15K
- 1991. 10 ● 유회전식 진공펌프 개발
  - 모터직결 베인형 : D5A, D10A, D20A, D35A, D55A, D85A
- 1997. 08 ● 유회전식 진공펌프 개발
  - 모터직결 피스톤형 : WSDM5K, 7.5K
- 1998. 06 ● 유회전식 진공펌프 개발
  - 모터직결 베인펌프 : TRP-6, TRP-12, TRP-24, TRP-36, TRP-48, TRP-60, TRP-90
- 1999. 08 ● 벤처기업 선정(중소기업청 지정)
- 2001. 09 ● 한국품질재단으로부터 ISO9001 인증 취득
- 2002. 05 ● UL인증 취득
- 2002. 06 ● 부스터진공펌프 개발
  - WRU : 12K, 18K, 24K, 36K, 48K
- 2005. 01 ● 모터 직결형 베인 타입 진공펌프 제작
  - MVP-6, 12, 24, 36, 60, 90, 144, 216, 324
- 2006. 09 ● 부스터 진공펌프 제작
  - FRU 180, 360, 720, 1440, 2880
- 2007. 03 ● ISO 9001 : 2008 인증 취득 (ICR)
- 2009. 03 ● ISO 14001 : 2004 인증 취득 (ICR)
- 2009. 11 ● CE & TI 인증 취득
- 2009. 11 ● 드라이 펌프 MDP-96, 144, 216, 324, 480, 720 출시
- 2011. 01 ● 드라이 펌프 관련 특허 취득 (한국, 인도, 미국, 중국)
- 2013. 05 ● ISO9001/14001 갱신
- 2014. 07 ● CE 인증 갱신 MVP, FRU, SUPER 시리즈
- 2014. 09 ● MVP 특허 획득
- 2014. 09 ● 제 1 제주 공장 설립 및 본사 제주 이전
- 2015. 02 ● 신제품 Super 시리즈 출시
- 2015. 07 ● 제2 인천공장 이전
- 2016. 06 ● 신제품 ATS 시리즈 출시
- 2017. 03 ● 신제품 WSS 시리즈 출시
- 2017. 03 ● 기술 개발 연구소 등록
- 2017. 07 ● 수출 유망기업 자격 획득
- 2018. 01 ● WST, WSR, WSD 출시

## HISTORY

- 1976. 11 ● Established and manufacture spare part of vacuum pumps
- 1978. 02 ● Development of Oil Rotary Vacuum Pump
- 1986. 11 ● Award Prize of the Minister of Commerce and Industry as prominent company of superior domestic machine developmen
- 1988. 04 ● Converted into Woosung Vacuum Corporation Ltd
- 1990. 06 ● Development of Oil Rotary Vacuum Pump
  - Vane Type 2 stage : WSVP9018, WSVP9030, WSVP9060
  - Piston Type : WSSR-1.5K, 2.5K, 4.5K, 7.5K, WSDR-15K
- 1991. 10 ● Development of Oil Rotary Vacuum Pump
  - Motor Direct Driven vane type : D5A, D10A, D20A, D35A, D55A, D85A
- 1997. 08 ● Development of Oil Rotary Vacuum Pump
  - Motor Direct Driven Piston type : WSDM5K, 7.5K
- 1998. 06 ● Development of Oil Rotary Vacuum Pump
  - Motor Direct Driven vane type : TRP-6, TRP-12, TRP-24, TRP-36, TRP-48, TRP-60, TRP-90
- 1999. 08 ● Certificated ISO9001 from KFQ
- 2001. 09 ● Acquired ISO 9001 certification
- 2002. 05 ● Certificated UL
- 2002. 06 ● Development of Roots Vacuum Pump
  - WRU : 12K, 18K, 24K, 36K, 48K
- 2005. 01 ● Development of Motor Direct Driven Vane Type vacuum pump
  - MVP-6, 12, 24, 36, 60, 90, 144, 216, 324
- 2006. 09 ● Development of Booster Vacuum Pump
  - FRU 180, 360, 720, 1440, 2880
- 2007. 03 ● Certificated ISO 9001:2008 from ICR
- 2009. 03 ● Certificated ISO 14001:2004 from ICR
- 2009. 11 ● Certificated CE MVP,FRU
- 2009. 11 ● Development of Dry vacuum pumps (MDP series)
- 2011. 01 ● Patent Multi-Dry vacuum pumps  
(Korea, India, USA and China)
- 2013. 05 ● Renew ISO9001/14001
- 2014. 07 ● Renew CE for MVP,FRU,SUPER series
- 2014. 09 ● Patent MVP series
- 2014. 09 ● Established 1st factory and transferred Head office in Jeju
- 2015. 02 ● Release new Super series
- 2015. 07 ● Transferred Incheon factory and Gimp warehouse
- 2016. 06 ● Release new ATS series
- 2017. 03 ● Release new WSS series
- 2017. 03 ● R&D LAB registered
- 2017. 07 ● Designed Promising Export Firm
- 2018. 01 ● Release New WST, WSR and WSD pump



# Contents

---

Oil Rotary Vacuum Pump

## Vane Single Stage

**WATS** - WATS 0020 / 0030 / 0040 / 0060 / 0080 / 0130 / 0200 10

- WATS 0350 / 0500 / 0600 / 0800 / 1000 / 1200



**WSS-B** - WSS 120B / 180B / 240B / 360B / 480B 20



---

Oil Rotary Vacuum Pump

## Vane Dual Stage

**MVP SMALL** - MVP 6 / 12 / 24 / 36 / 60 / 90 26



**MVP LARGE** - MVP 144 / 216 / 324 / 432 / 540 30



**WST** - WST 180B / 324B 34



**WSVP** - WSVP 2120 / 2130 / 2150 38



---

Oil Rotary Vacuum Pump

## Piston

**WSSR-V** – WSSR V1.5K / V2.5K / V4.8K / V7.5K 42



---

## DRY Screw Pump

**TDP** – TDP 150 / 250 / 400 / 800 / 1500 48



**MDP** – MDP 150S / 300S / 400S / 800S / 1000S / 1500S 52



**MDP-B** – MDP 300B / 400B / 600B / 800B 56



---

## Mechanical Booster

**FRU** – FRU 180 / 360 / 720 / 1440 / 2880 / 5800 62



---

## Accessory

OIL MIST TRAP – TMF SERIES 66  
INLET TRAP – WSL SERIES  
OIL MIST TRAP – WSG SERIES  
INLET TRAP ELEMENT  
OIL MIST TRAP ELEMENT  
VACUUM FITTING



**OIL ROTARY VACUUM PUMP SINGLE STAGE**

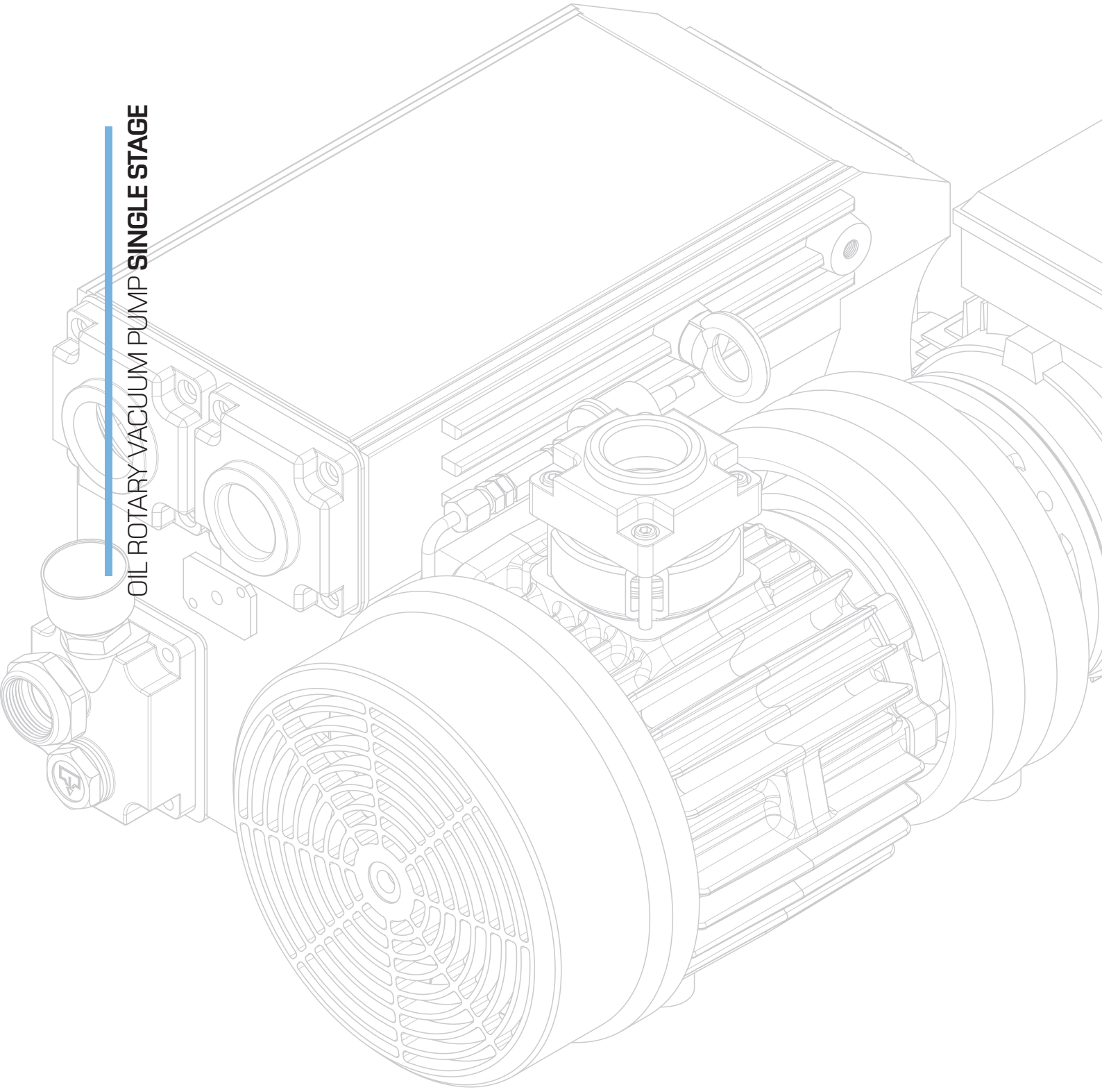

# Oil Rotary VACUUM Pump **Vane Single Stage**

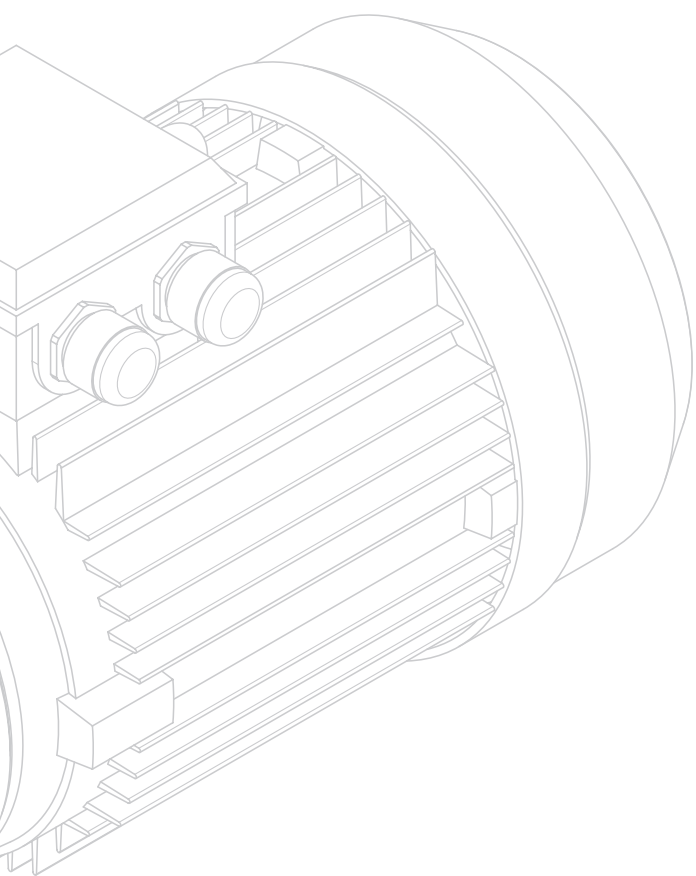

## **WATS**

- WATS 0020 / 0030 / 0040  
0060 / 0080 / 0130  
0200
- WATS 0350 / 0500 / 0600  
0800 / 1000 / 1200

---

## **WSS-B**

- WSS 120B / 180B / 240B  
360B / 480B



## VANE SINGLE STAGE

### WATS

---

- WATS 0020 / 0030 / 0040  
0060 / 0080 / 0130  
0200

- WATS 0350 / 0500 / 0600  
0800 / 1000 / 1200



### DETAIL

---

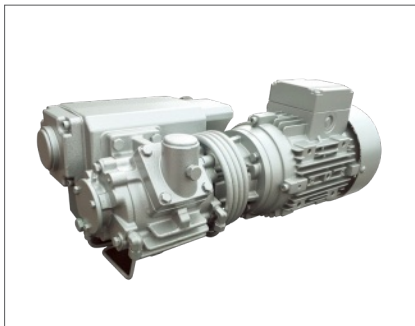

WATS 0020 / 0030 / 0040



WATS 0060 / 0080



WATS 0130 / 0200



WATS 0350



WATS 0500 / 0600



WATS 0800 / 1000 / 1200

## EXTERNAL PUMP SKETCH

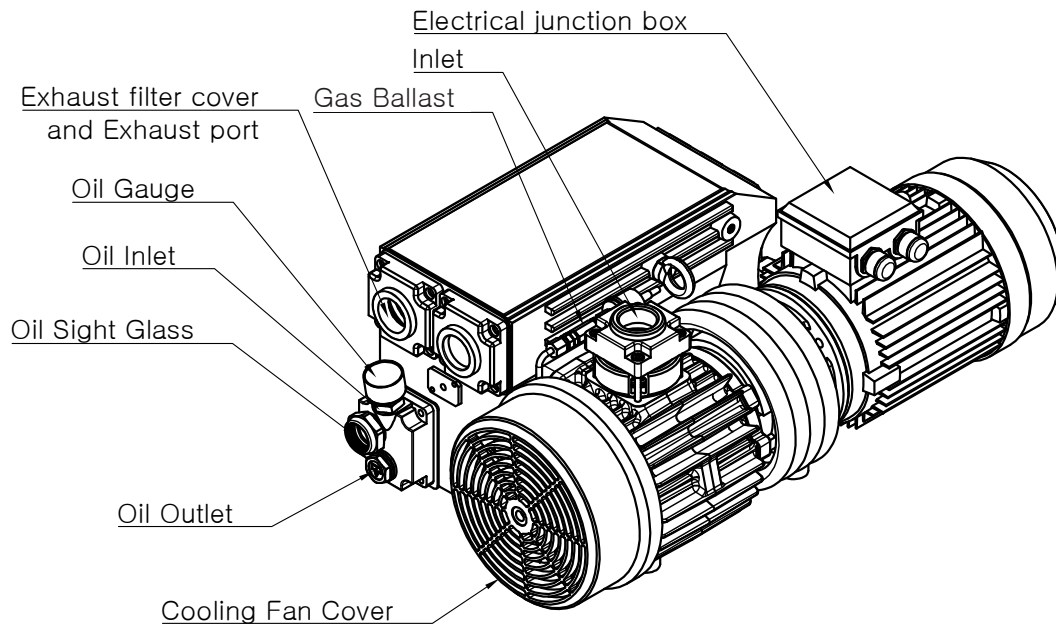

## DESIGN FEATURE

1. 오일을 회수하는 구조로 오일의 소모를 최소화 한다.
2. 오일미스트필터가 내장되어 배출되는 오일미스트를 완벽하게 잡아 환경오염을 방지한다.
3. 오일미스트필터의 단면을 크게하여 오일미스트필터의 수명이 길다.
4. 오일게이지, 오일주입구, 오일배출구가 한 방향에 있어, 점검 및 관리가 편리하다.
5. 대기압에서 연속적으로 작업이 가능하다.
6. 디자인이 간결하며 내구성이 우수하다.
7. 간단한 설치가 가능하다.
8. 공랭식 구조로 냉각수가 불필요하다.

1. The intergrated oil circulation system minimizes oil loss.
2. The built-in filters are prevented to occur air pollution.
3. The surface of oil mist filter is improved for long life cycle.
4. The oil gauge, oil inlet and oil outlet is located at same side for easier maintenance.
5. The pumps are capable of continuative operation under ambient pressure.
6. The composition of pump is simple, convenient for maintenance manager.
7. The installation work is simple.
8. The cooling water is not required by using air-cooled structure.

# VANE SINGLE STAGE

## TECHNICAL DATA

DESCRIPTION		UNIT	0020	0030	0040	0060	0080	0130	0200	0350	0500	0600	0800	1000	1200	
Nominal displacement	60Hz	m <sup>3</sup> /h	12	18	24	36	48	78	120	210	300	360	505	600	780	
	50Hz		10	15	20	30	40	65	100	175	250	300	420	500	660	
Ultimate pressure		mbar (Torr)	20(15)				0.1(0.075)									
Inlet Port			1/2"			1-1/4"			2"				3"			
Outlet Port			1-1/4"			1-1/4"			2"				3"			
Motor		kW	0.4	0.75	0.9	1.1	1.5	2.2	3	5.5	7.5	9.2	15	15	18.5	
Nominal motor speed	50Hz	R.P.M	1740		3480	1740			1740				1160			
	60Hz		1450		2870	1450			1450				980			
Noise level(50Hz/60Hz)		dB	57/59	58/60	60/62	64/67	64/67	65/68	65/68	74/77	74/77	85	78	79	79	
Oil capacity(min/max)		L	0.5	0.5	0.5	1.4	1.4	2.5	2.7	7	8	8	19	19	19	
Weight		Kg	20	22	20	47	53	66	75	164	184	188	504	544	703	

## APPLICATIONS

포장작업 공정 : 식품진공포장, MAP포장, 성형포장, 블리스터 포장, 튜브포장기 포일운송  
 가스제거 공정 : 식품생산, 플라스틱 압출, 진공주조, 진공함침, 열처리, 표면코팅, 진공용기  
 코팅작업 공정 : 금속, 플라스틱, 유리의 코팅 - 라미네이팅 공정 : 태양전지 제품, LCD, 휴대폰 디스플레이  
 건조작업 공정 : 식품의 동결건조, 분유생산, 슬러지건조, 목재건조, 합성수지 입자 건조  
 증류작업 공정 : 원유증류, 제약 및 화학분야의 진공 증류  
 이송작업 공정 : 병원의 흡입이송, 식품의 이송, 플라스틱 제품의 이송, 수분함유 폐기물 이송  
 고정작업 공정 : 금속, 비금속, 플라스틱 흡착 고정

Packing : food vacuum, MAP, forming, blister and tube packing

Degassing : food industry, plastic injection press, vacuum casting, vacuum impregnation, heat treatment, surface coating

Coating : coating at metal, plastic, glass, etc

Lamination : solar battery products, LCD, mobile phone display

Drying : food freeze-drying, milk powder production, sludge drying, wood drying, synthetic resin particle drying

Distillation : oil distillation, vacuum distillation in chemical and pharmaceutical industry

Transfer : inhale transfer in hospital, food transfer, plastic transfer, water vapour containing waste transfer

Fix : suction mounting



# OUTSIDE DIMENSION

## WATS 0020 / 0030 / 0040

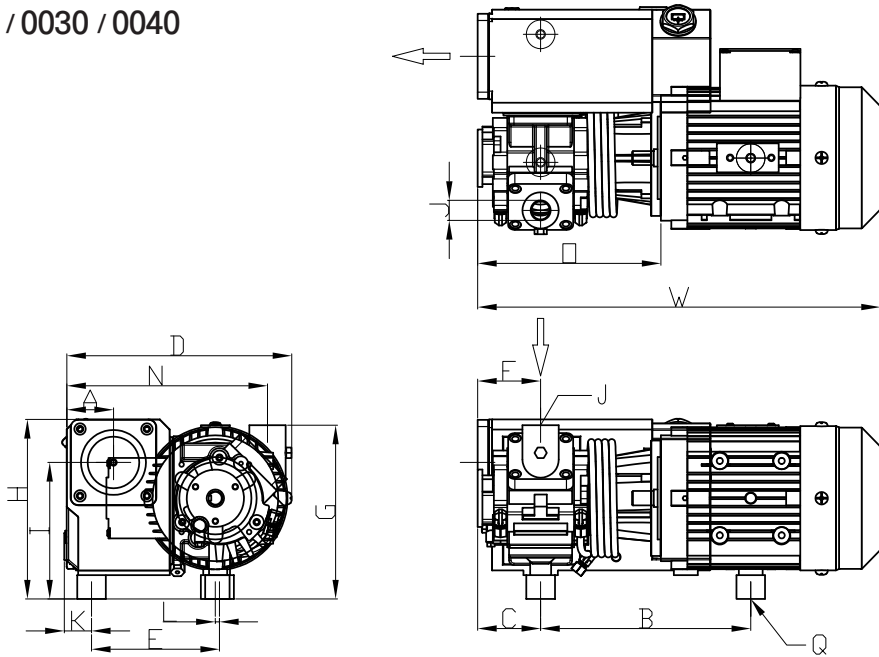

Model	W	D	H	A	B	C	E	F	G	I	J	K	L	M	N	O	Q
0020	422				220	66		66								192	3xM8
0030	452	258	188	49	235	81	134	81	182	143	1/2"	29	4	1-1/4"	210	222	
0040	422				220	66		66								2192	

## WATS 0060 / 0080

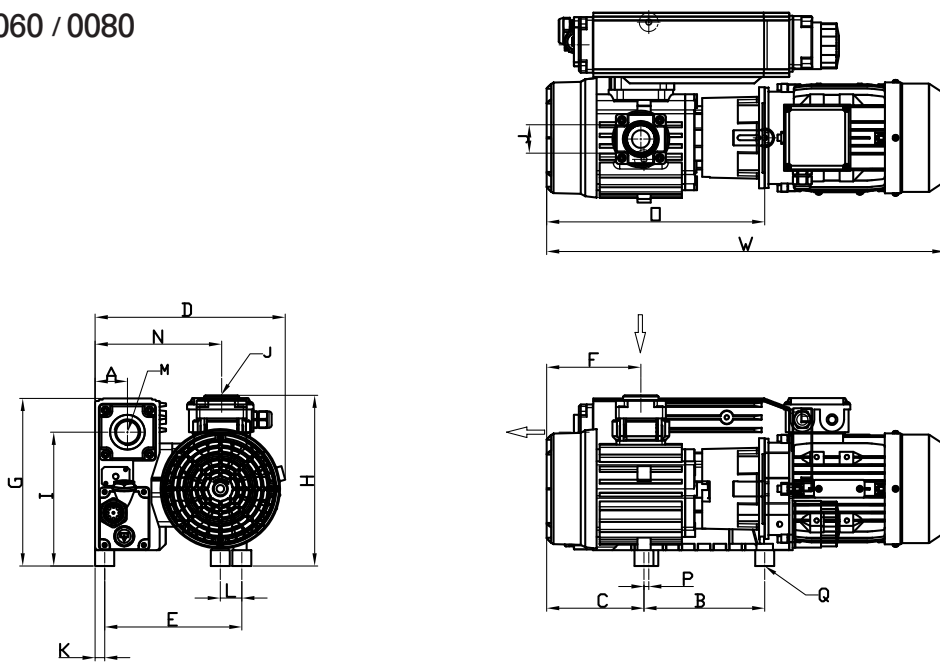

Model	W	D	H	A	B	C	E	F	G	I	J	K	L	M	N	O	P	Q
0060	575	301	270	50	176	139	217	134	265	212	1-1/4"	15	34	1-1/4"	200	315	7.5	3xM8
0080	630				191	154		149								345		

# VANE SINGLE STAGE

## OUTSIDE DIMENSION

### WATS 0130 / 0200

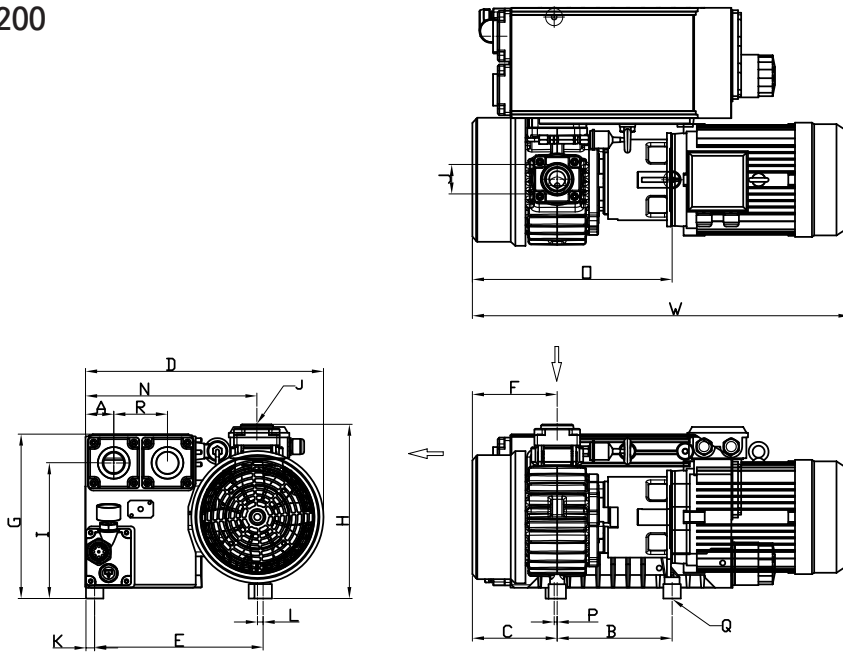

Model	W	D	H	A	B	C	E	F	G	I	J	K	L	M	N	O	P	Q	R
0130	654	412	302	49	199	147	292	147	285	235	1-1/4"	15	10	1-1/4"	297	346	5.3	3xM8	93
0200	704				224	172		172								396			

### WATS 0350

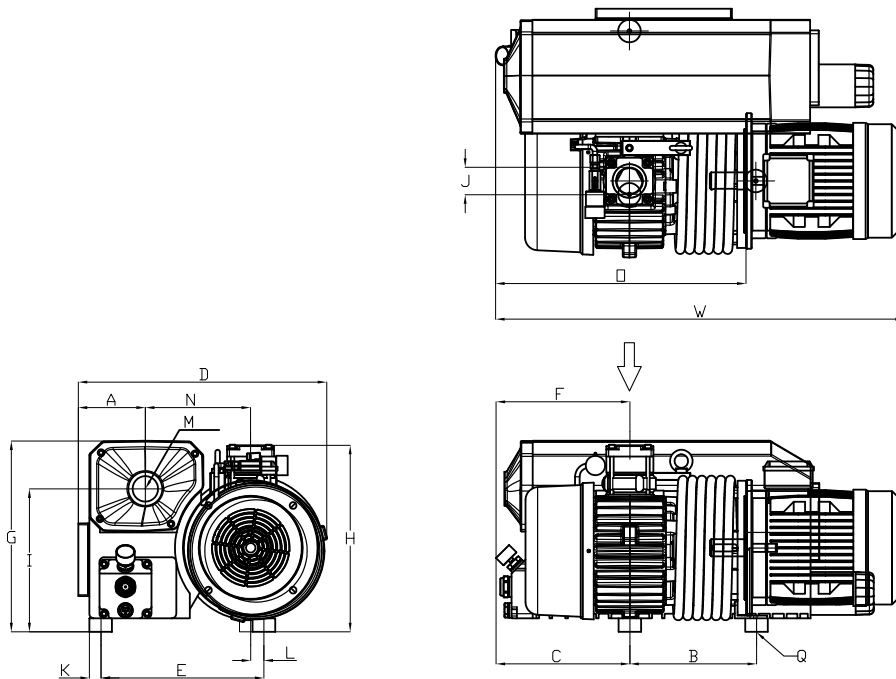

Model	W	D	H	A	B	C	E	F	G	I	J	K	L	M	N	O	Q
0350	905	529	413	148	280	296	360	294	423	316	2"	50	29	2"	233	554	3xM10

WATS 0500 / 0600

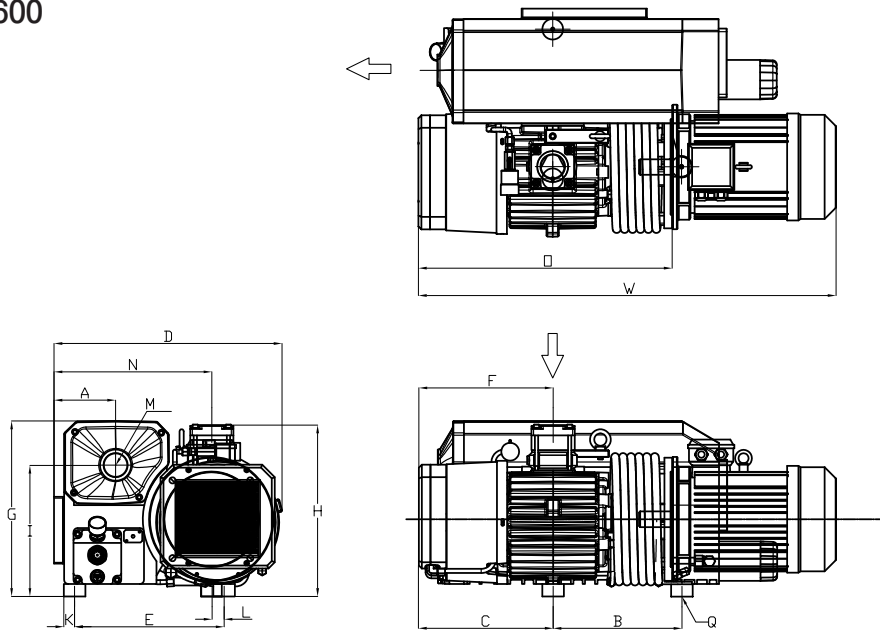

Model	W	D	H	A	B	C	E	F	G	I	J	K	L	M	N	O	Q
0500	1006	550	413	149	311	323	360	324	426	316	2"	50	29	2"	380	612	3xM10
0600	1032												31				

WATS 0800 / 1000 / 1200

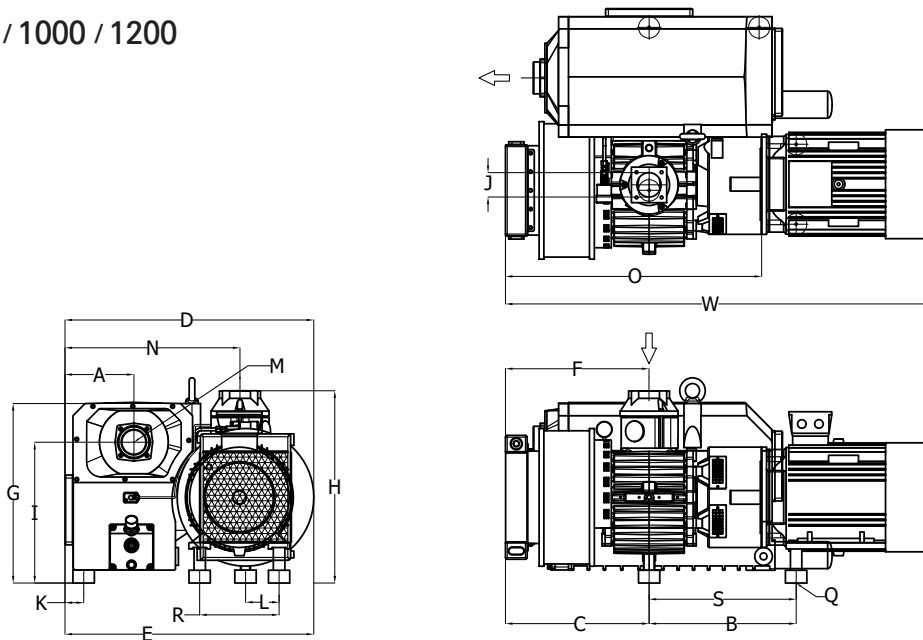

Model	W	D	H	A	B	C	E	F	G	I	J	K	L	M	N	O	Q	R	S
0800	1484	874	671	242	417	494	569	494	631	491	3"	65	138	3"	614	889	4xM12	279	387
1000	1583				549	559		559					118			988		279	
1200	1747				636	595		595					118			1097		318	



# VANE SINGLE STAGE

## PUMPING SPEED CURVE

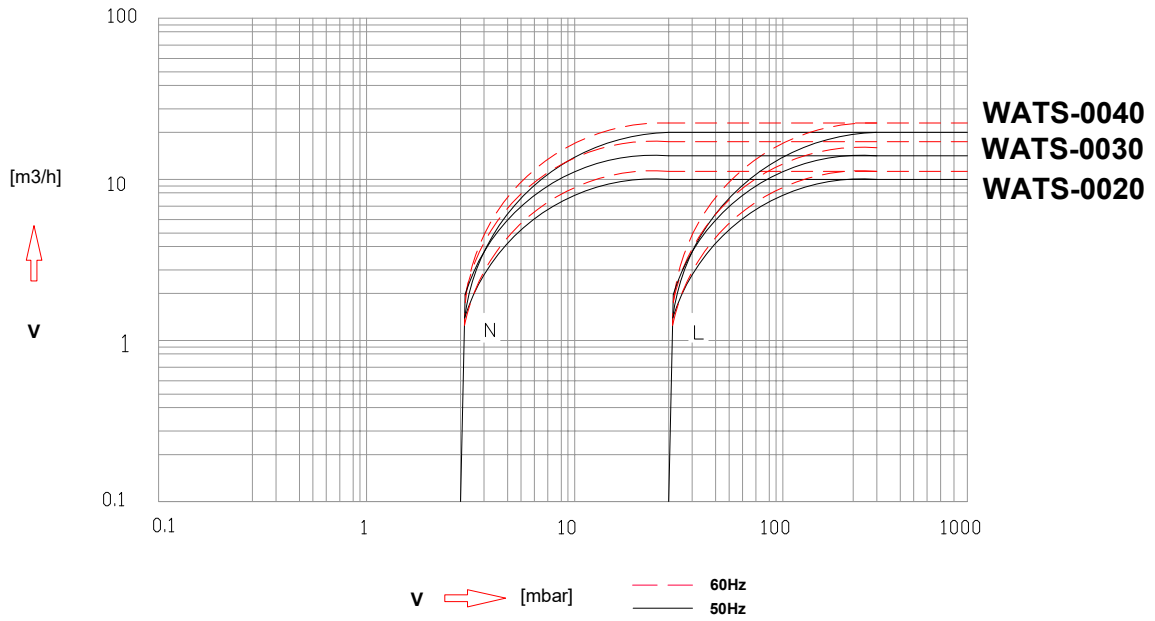

## PUMPING SPEED CURVE

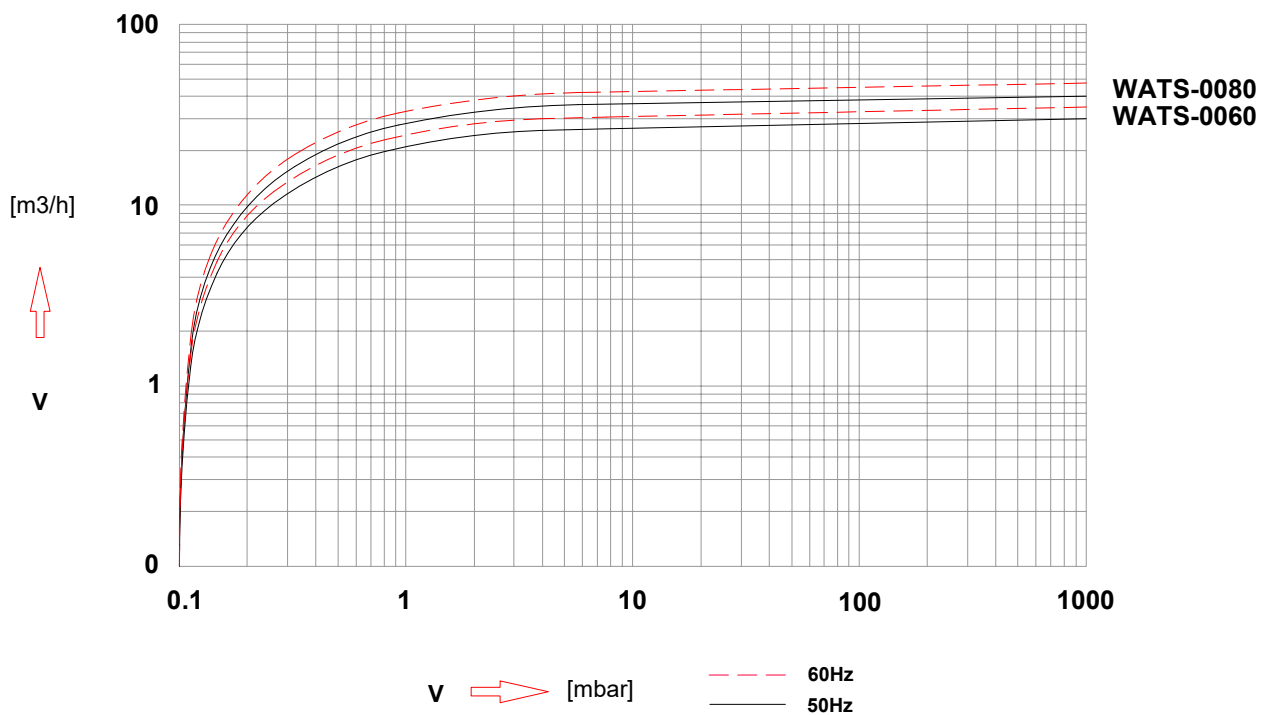

## PUMPING SPEED CURVE

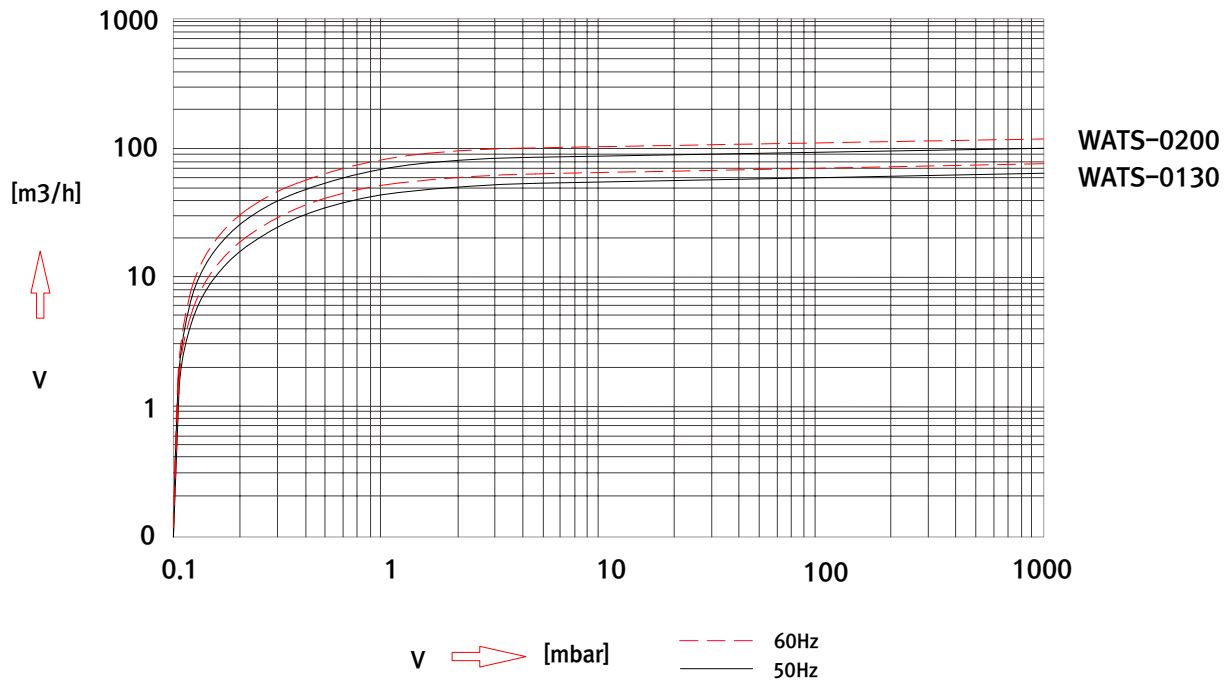

## PUMPING SPEED CURVE

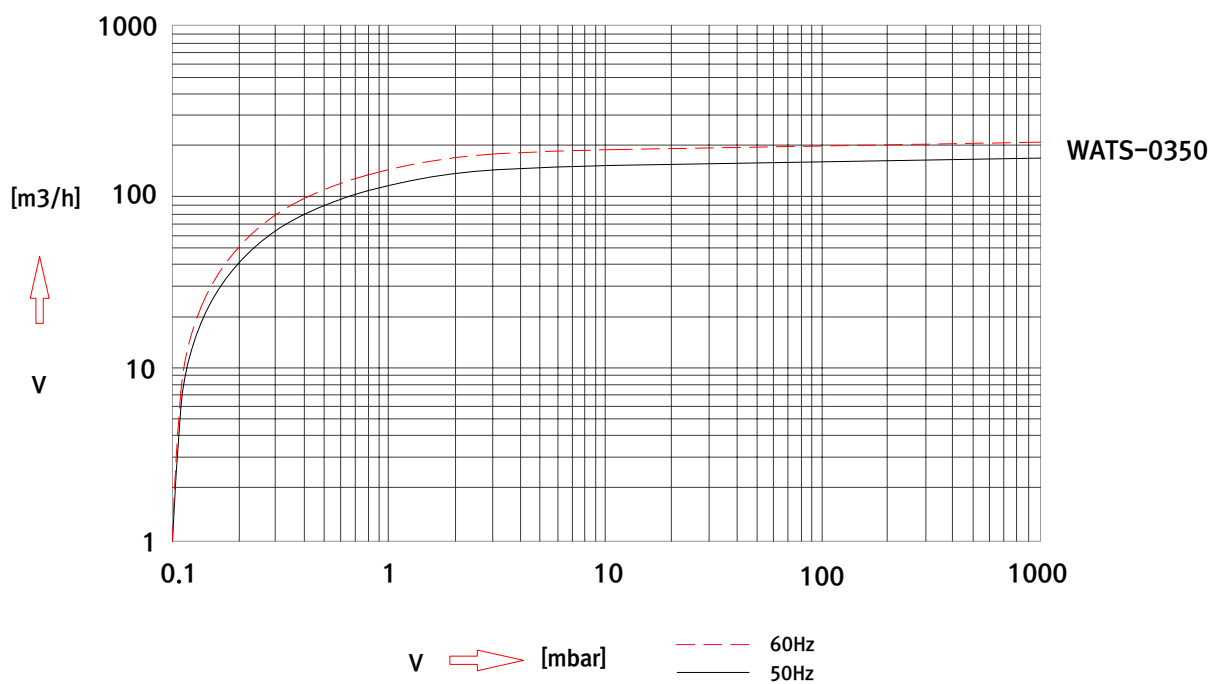

# VANE SINGLE STAGE

## PUMPING SPEED CURVE

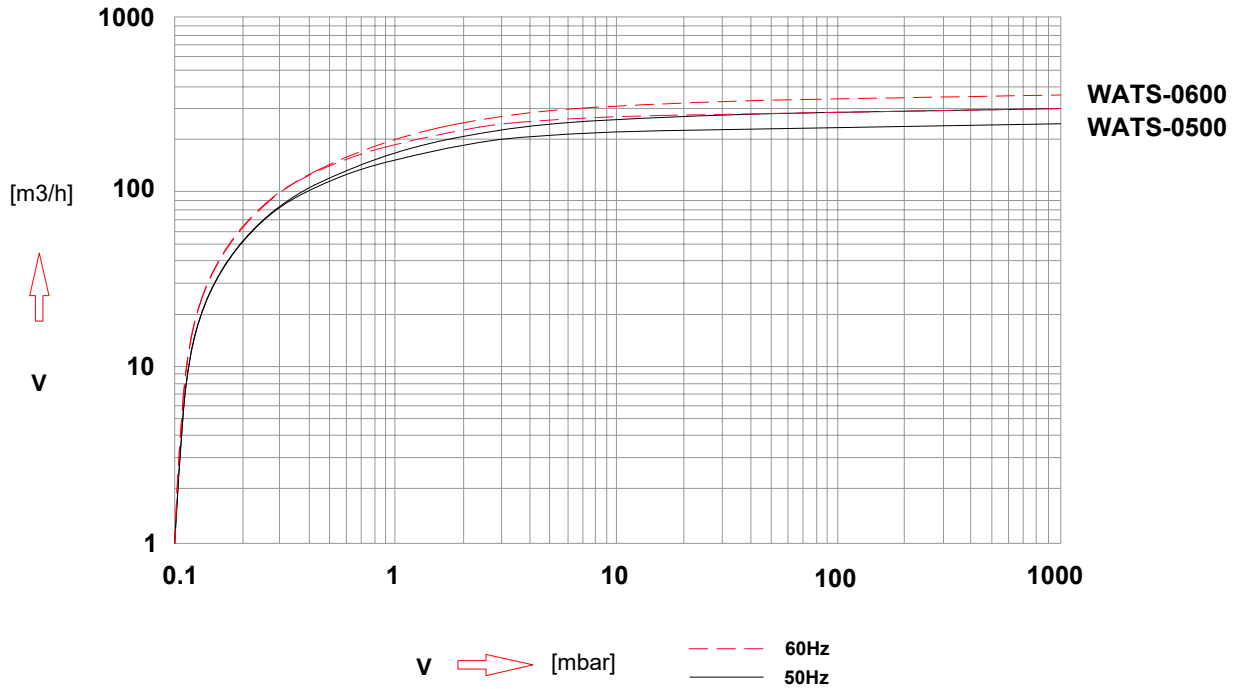

## PUMPING SPEED CURVE

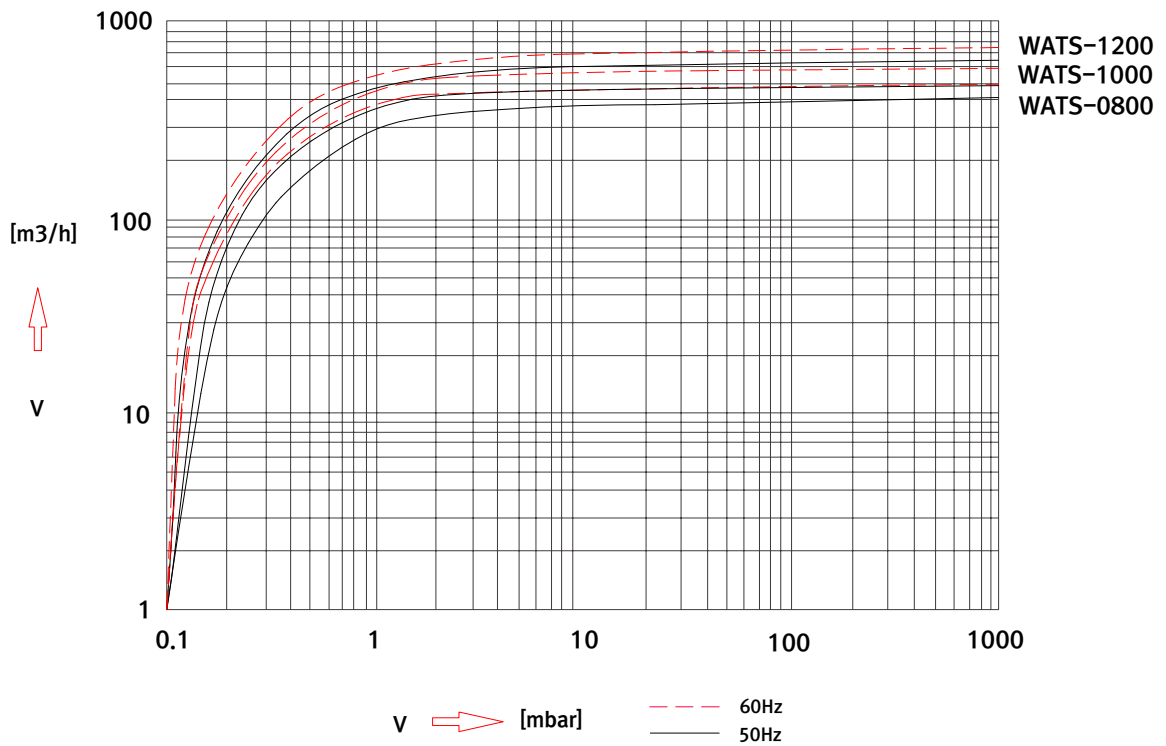

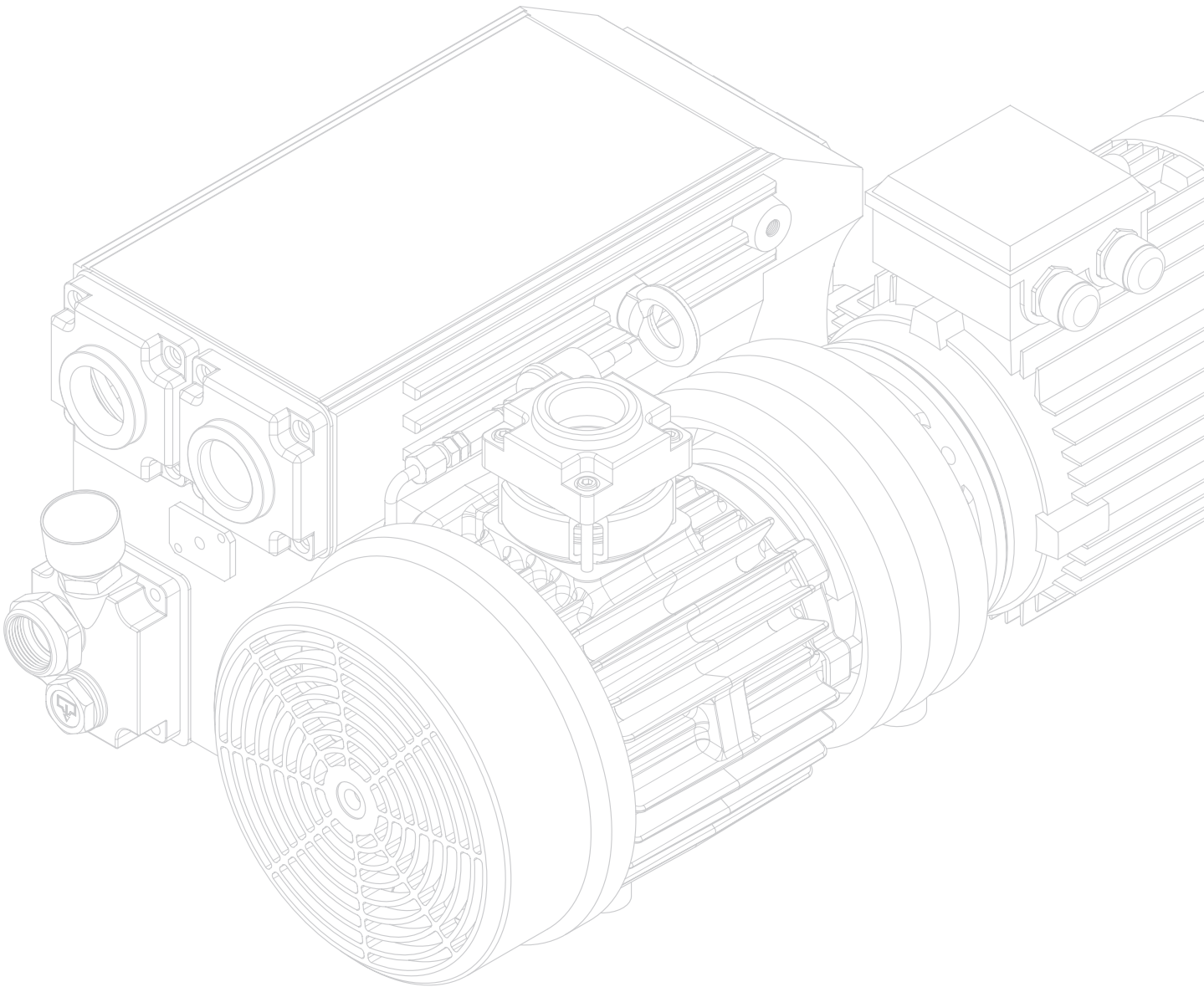



## VANE SINGLE STAGE

### WSS-B

- WSS 120B / 180B / 240B  
360B / 480B



### DETAIL



## EXTERNAL PUMP SKETCH

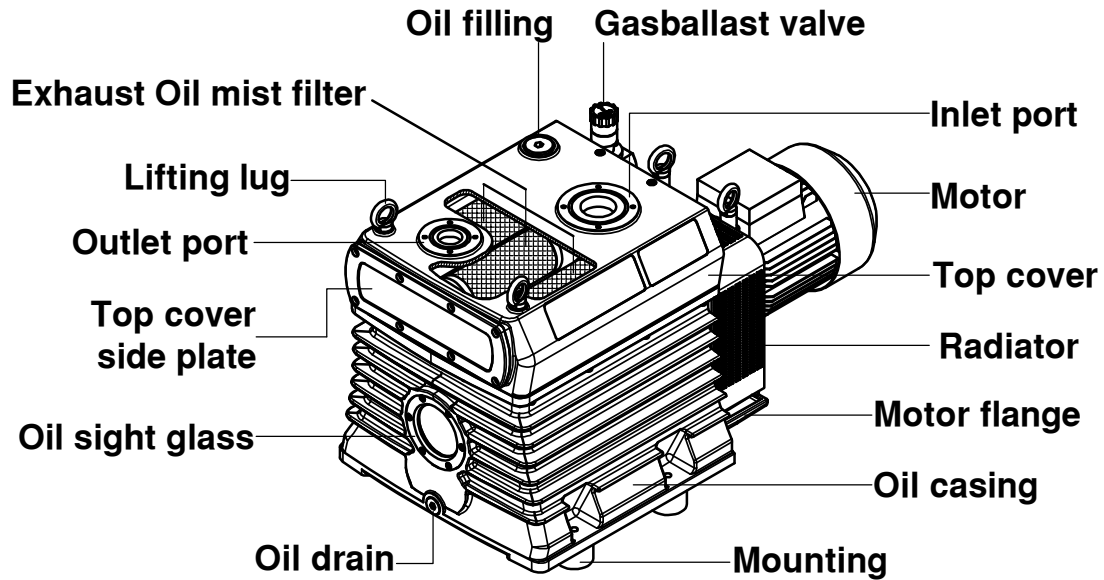

## DESIGN FEATURE

1. 라디에이터 공랭식 냉각구조로 펌프의 온도가 매우 낮아 가혹한 작업공정에 이상적이다.
  2. 낮은 오일온도는 펌프의 사용시간을 길게 하고 안정된 펌프 성능을 유지한다.
  3. 오일의 양을 크게 하여 오일의 수명이 길다.
  4. 오일을 회수하는 구조로 오일의 소모를 최소화 한다.
  5. 흡입구에 위치한 역류방지밸브는 펌프 정지시 진공설비를 보호한다.
  6. 오일미스트필터가 내장되어 배출되는 유증기를 잡아 환경오염을 방지한다.
  7. 오일미스트필터의 단면을 크게하여 오일미스트필터의 수명이 길다.
  8. 오일게이지, 오일주입구, 오일배출구가 한 방향에 있어 점검 및 관리가 편리하다.
  9. 대기압에서 중진공영역의 진공작업에 적합하도록 특별히 설계된 제품으로 펌프 성능이 우수하다.
  10. 기압에서 연속적으로 작업이 가능하다.
  11. 소음이 작다.
1. The oil temperature of the pump is low due to efficient air cooling system with radiator and it is ideal it is ideal for harsh applications.
  2. The low oil temperature guarantees longer life time of pump and more stable performance.
  3. Big oil volume for long oil lifetime.
  4. Integrated oil recovery system to minimize oil loss.
  5. The anti-suckback valve located at the inlet port protects the vacuum chamber at the time of sudden pump stop.
  6. Integrated oil mist filter at the outlet port of the pump to prevent pollution.
  7. Big cross-sectional area of oil mist filter for long life time of the filter
  8. The oil gauge, oil inlet, and oil outlet is located at same side for easier maintenance.
  9. The pump is specially designed to have optimum performance from the low to medium vacuum.
  10. The pump are capable of continuative operation under ambient pressure.
  11. Noise level is low.

# VANE SINGLE STAGE

## TECHNICAL DATA

DESCRIPTION		UNIT	WSS 120B	WSS 180B	WSS 240B	WSS 360B	WSS 480B
Nominal displacement	50Hz	m <sup>3</sup> /h	100	150	200	300	400
	60Hz		120	180	240	360	480
Ultimate pressure without gas ballast		mbar (Torr)	0.08(0.06)				
Ultimate pressure with gas ballast(I)			0.5(0.375)				
Ultimate pressure with gas ballast(II)			1(0.75)				
Inlet Port		ISO63(2")					ISO80(3")
Outlet Port							
Motor Power (50Hz/60Hz)		kW	2.2/3.0	3.7	3.7/5.5	7.5	11
Type of protection		IP55					
Nominal motor speed	50Hz	R.P.M	1500				
	60Hz		1720				
Water vapour tolerance	50Hz	mbar	30		40		
	60Hz		30		50		
Noise level(50Hz/60Hz)		dB	66/70		70/74		72/76
Oil capacity(min/max)		L	16		20		
Weight		Kg	150	170	225	242	310

## PUMPING SPEED CURVE

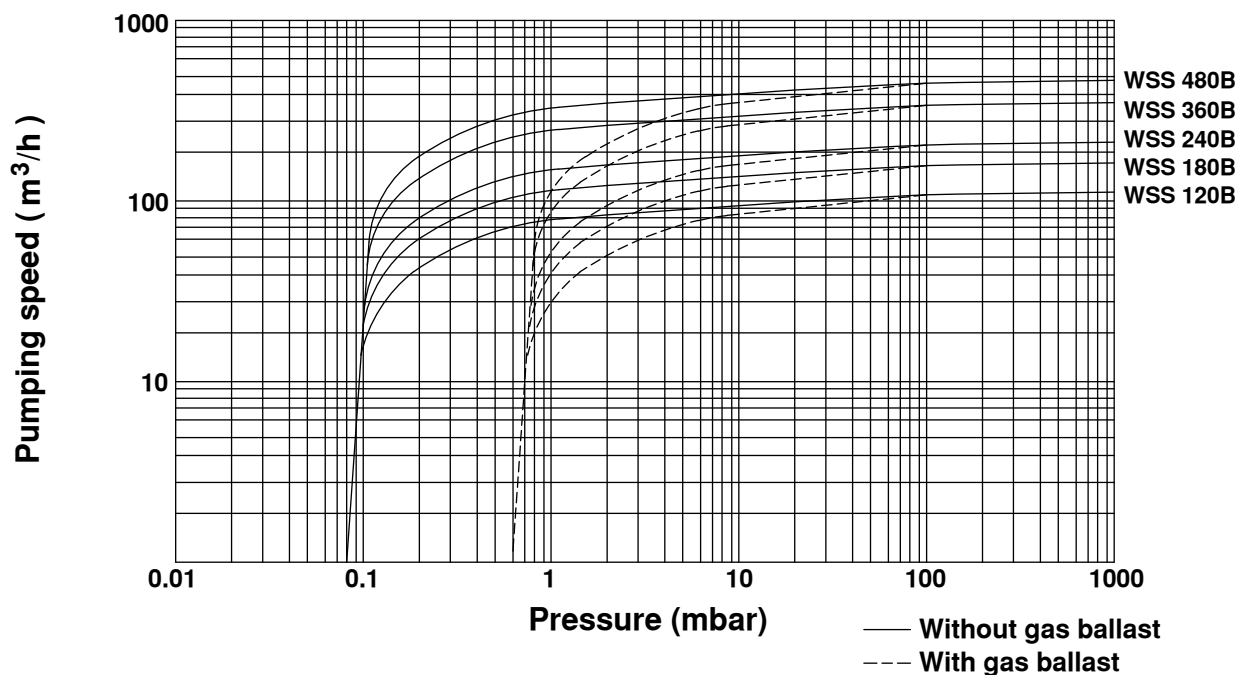

## OUTSIDE DIMENSION

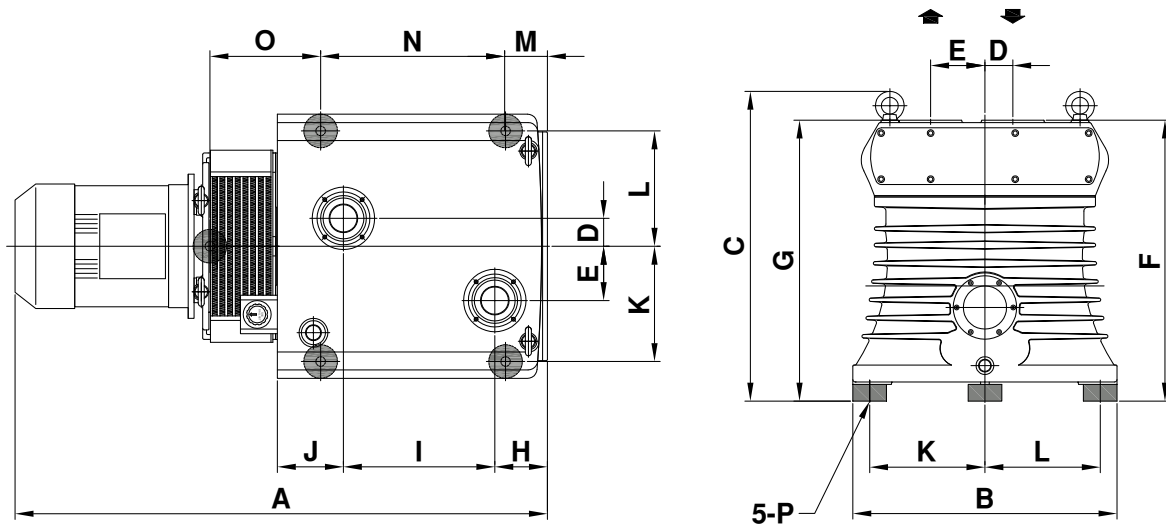

Model	A	B	C	D	E	F	G	H	I	J	K	L	M	N	O	P
WSS 120B	953	460	565	50	57.5	505	505	113		225	125	200	200	134	210	243
WSS 180B										225	125	200	200	134	210	243
WSS 240B	1108	550	645	58	113	585	585	109.5	315	137.5	240	240	87	385	230.5	M10
WSS 360B	1108	550	645	58	113	585	585	109.5	315	137.5	240	240	87	385	230.5	
WSS 480B	1341	550	690	58	113	630	630	146.5	380	137.5	240	240	189	385	242.5	

## APPLICATIONS

포장작업 공정 : 식품진공포장, MAP포장, 성형포장, 블리스터 포장, 튜브포장기 포일운송

가스제거 공정 : 식품생산, 플라스틱 압출, 진공주조, 진공함침, 열처리, 표면코팅, 진공용기

코팅작업 공정 : 금속, 플라스틱, 유리의 코팅 - 라미네이팅 공정 : 태양전지 제품, LCD, 휴대폰 디스플레이

건조작업 공정 : 식품의 동결건조, 분유생산, 슬러지건조, 목재건조, 합성수지 입자 건조

중류작업 공정 : 원유중류, 제약 및 화학분야의 진공 중류

이송작업 공정 : 병원의 흡입이송, 식품의 이송, 플라스틱 제품의 이송, 수분함유 폐기물 이송

고정작업 공정 : 금속, 비금속, 플라스틱 흡착 고정

Packing : food vacuum, MAP, forming, blister and tube packing

Degassing : food industry, plastic injection press, vacuum casting, vacuum impregnation, heat treatment, surface coating

Coating : coating at metal, plastic, glass, etc

Lamination : solar battery products, LCD, mobile phone display

Drying : food freeze-drying, milk powder production, sludge drying, wood drying, synthetic resin particle drying

Distillation : oil distillation, vacuum distillation in chemical and pharmaceutical industry

Transfer : inhale transfer in hospital, food transfer, plastic transfer, water vapour containing waste transfer

Fix : suction mounting



**OIL ROTARY VACUUM PUMP DUAL STAGE**

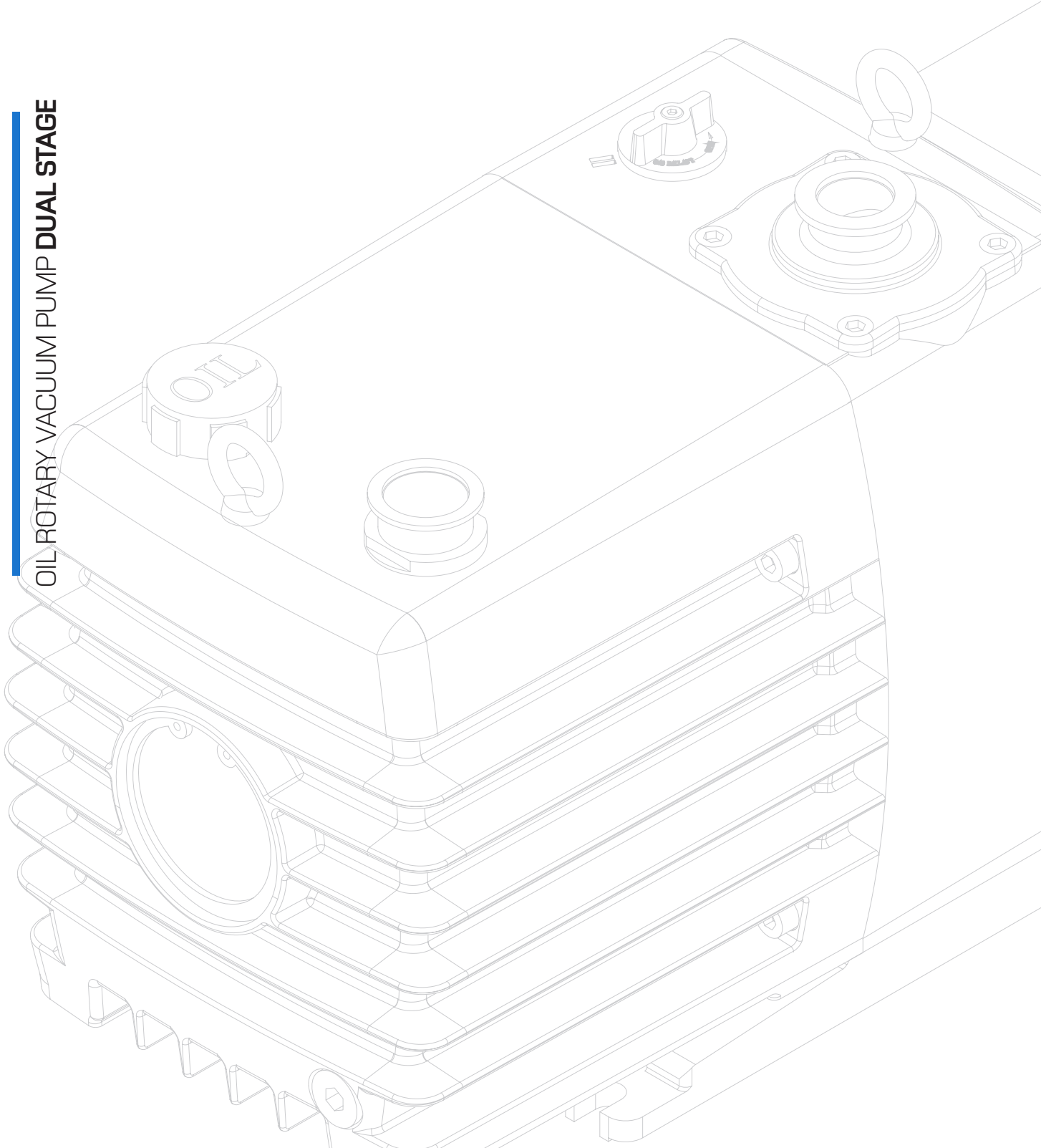

# Oil Rotary VACUUM Pump **Vane Dual Stage**

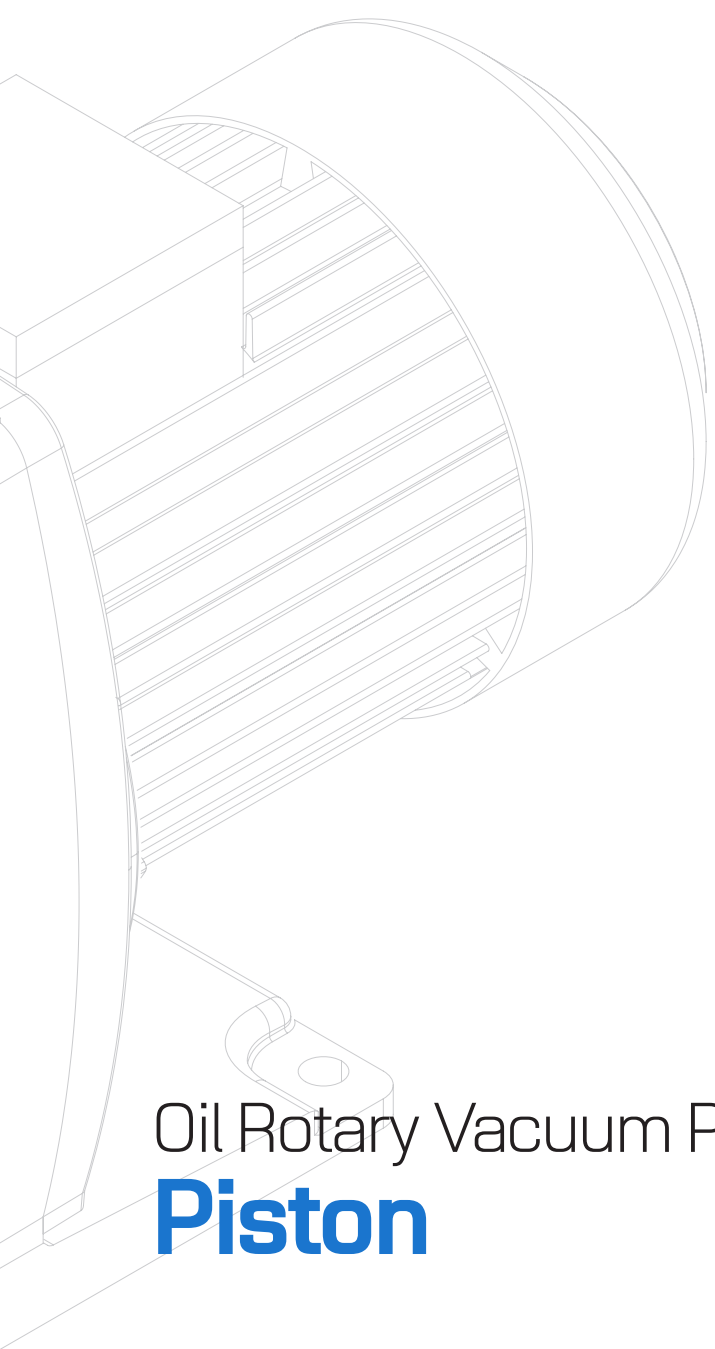

## Oil Rotary Vacuum Pump **Piston**

### **MVP SMALL**

– MVP 6 / 12 / 24 / 36  
/ 60 / 90

---

### **MVP LARGE**

– MVP 144 / 216  
/ 324 / 432 / 540

---

### **WST**

– WST 180B / 324B

---

### **WSVP**

– WSVP 2120 / 2130 / 2150

### **WSSR-V**

– WSSR V1.5K / V2.5K /  
V4.8K / V7.5K

# VANE DUAL STAGE

## MVP SMALL

- MVP 6 / 12 / 24 / 36  
60 / 90



## DETAIL



## EXTERNAL PUMP SKETCH

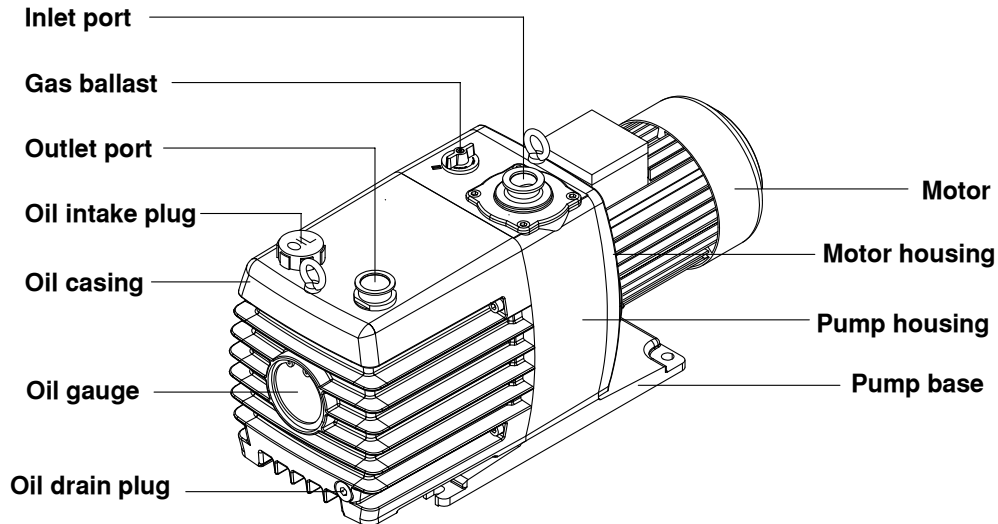

## DESIGN FEATURE

1. 고품질의 신소재를 사용하여 도달압력이 우수하고 배기속도가 크다.
2. 오일역류방지밸브 시스템이 펌프정지시 진공설비의 진공파기 및 오염을 막아준다.
3. 흡입구와 배기구는 국제규격에 따른 플랜지, 클램프를 사용한다.
4. 소음과 진동이 작다.
5. 강력한 오일압력을 가진 오일펌프가 오일순환을 완벽하게 하여 펌프를 보호한다.
6. 간단한 가스밸리스트밸브의 조정으로 펌프가 작동 중일 때도 사용이 가능하다.
7. 오일 점검과 오일교환이 편리하다.
8. 짧은 시간에 특별한 공구 없이 펌프를 수리할 수 있다.

1. Excellent ultimate vacuum and pumping speed by using high performance new materials.
2. Improved oil anti-suckback system to protect the vacuum system in the event of sudden stop.
3. Occupying international standard clamp and flange at inlet and outlet port.
4. Low noise and vibration.
5. Occupying strong and constant pressured oil circulating system to protect the pump.
6. Occupying convenient gas ballast valve control enabling open and shut-down of gas ballast valve easily while operating.
7. Simple maintenance and oil replacement.
8. Simple repair without special tools.

# VANE DUAL STAGE

## TECHNICAL DATA

DESCRIPTION		UNIT	MVP6	MVP12	MVP24	MVP36	MVP60	MVP90
Displacement Speed	60Hz	m <sup>3</sup> /h	6	12	24	36	60	90
		L/Min	100	200	400	600	1000	1500
	50Hz	m <sup>3</sup> /h	5	10	20	30	50	75
		L/Min	80	170	335	500	830	1250
Ultimate pressure	Gas ballast C	Torr	5 x 10 <sup>-4</sup>					
	Gas ballast I		5 x 10 <sup>-3</sup>					
	Gas ballast II		5 x 10 <sup>-2</sup>					
Water vapour tolerance		Torr	40	40	25	25	40	40
Oil filling		L	1.1	1.2	2	2.3	4.5	6.5
Inlet Port		DN	25 KF				40 KF	
Outlet Port								
Motor Power (50Hz/60Hz)		KW	0.4		0.75		1.5	2.2
Rotational speed of pump	60Hz	R.P.M	1750					
	50Hz		1450					
Noise level (without gas ballast)		dB	50		52		56	
Weight		Kg	21	22.5	38	41	68	84

## PUMPING SPEED CURVE

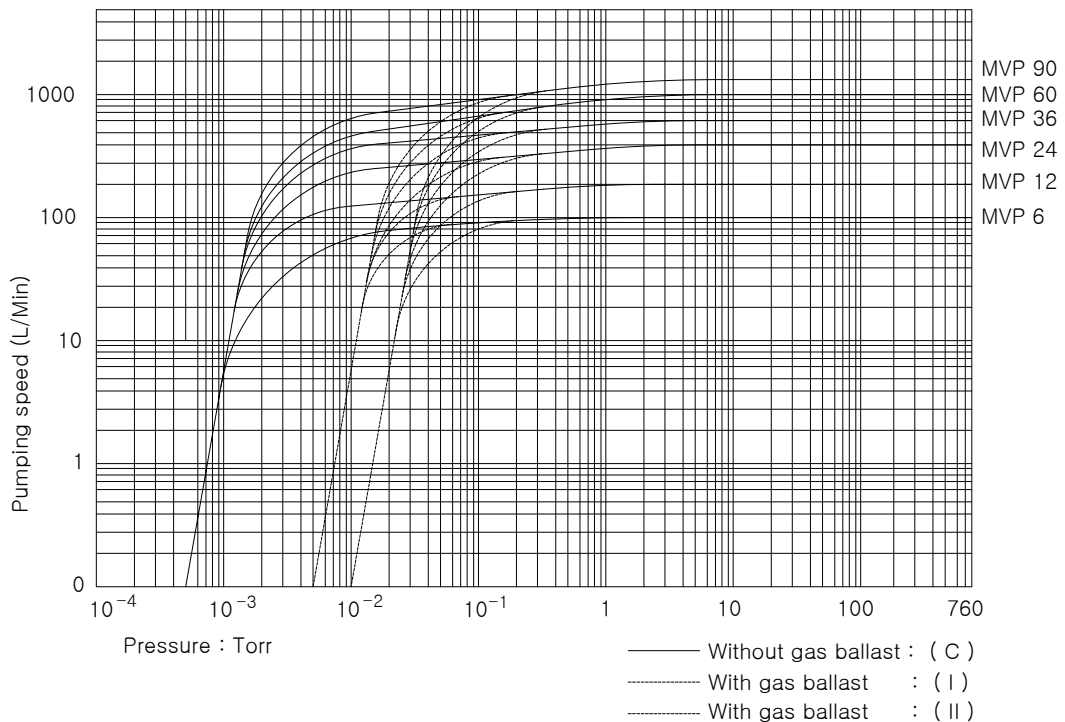



## OUTSIDE DIMENSION

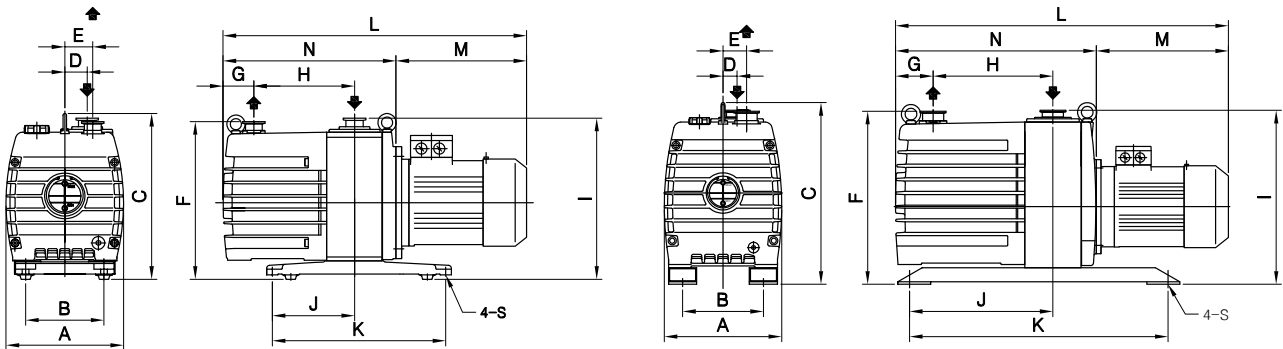

Model	A	B	C	D	E	F	G	H	I	J	K	N	S	M	L
MVP6	170	120	261	24	40	247	45	130	253	94	240	244	∅9	210	454
MVP12	170	120	261	24	40	247	45	155	253	94	240	269	∅9	210	479
MVP24	210	140	297	40	50	282	55	180	288	147	310	309	∅12	234	543
MVP36	210	140	297	40	50	282	58	210	288	147	310	342	∅12	234	576

Model	A	B	C	D	E	F	G	H	I	J	K	N	S	M	L
MVP60	250	185	387	30	50	368	80	255	370	305	550	428	∅14	281	709
MVP90	280	185	441	30	50	412	85	295	415	355	600	479	∅14	312	791

## APPLICATIONS

포장작업 공정 : 식품진공포장, MAP포장, 성형포장, 블리스터 포장, 튜브포장기 포일운송

가스제거 공정 : 식품생산, 플라스틱 압출, 진공주조, 진공함침, 열처리, 표면코팅, 진공용기

코팅작업 공정 : 금속, 플라스틱, 유리의 코팅 - 라미네이팅 공정 : 태양전지 제품, LCD, 휴대폰 디스플레이

건조작업 공정 : 식품의 동결건조, 분유생산, 슬러지건조, 목재건조, 합성수지 입자 건조

증류작업 공정 : 원유증류, 제약 및 화학분야의 진공 증류

이송작업 공정 : 병원의 흡입이송, 식품의 이송, 플라스틱 제품의 이송, 수분함유 폐기물 이송

고정작업 공정 : 금속, 비금속, 플라스틱 흡착 고정

Packing : food vacuum, MAP, forming, blister and tube packing

Degassing : food industry, plastic injection press, vacuum casting, vacuum impregnation, heat treatment, surface coating

Coating : coating at metal, plastic, glass, etc

Lamination : solar battery products, LCD, mobile phone display

Drying : food freeze-drying, milk powder production, sludge drying, wood drying, synthetic resin particle drying

Distillation : oil distillation, vacuum distillation in chemical and pharmaceutical industry

Transfer : inhale transfer in hospital, food transfer, plastic transfer, water vapour containing waste transfer

Fix : suction mounting

# VANE DUAL STAGE

## MVP LARGE

- MVP 144 / 216  
/ 324 / 432 / 540



## DETAIL



## EXTERNAL PUMP SKETCH

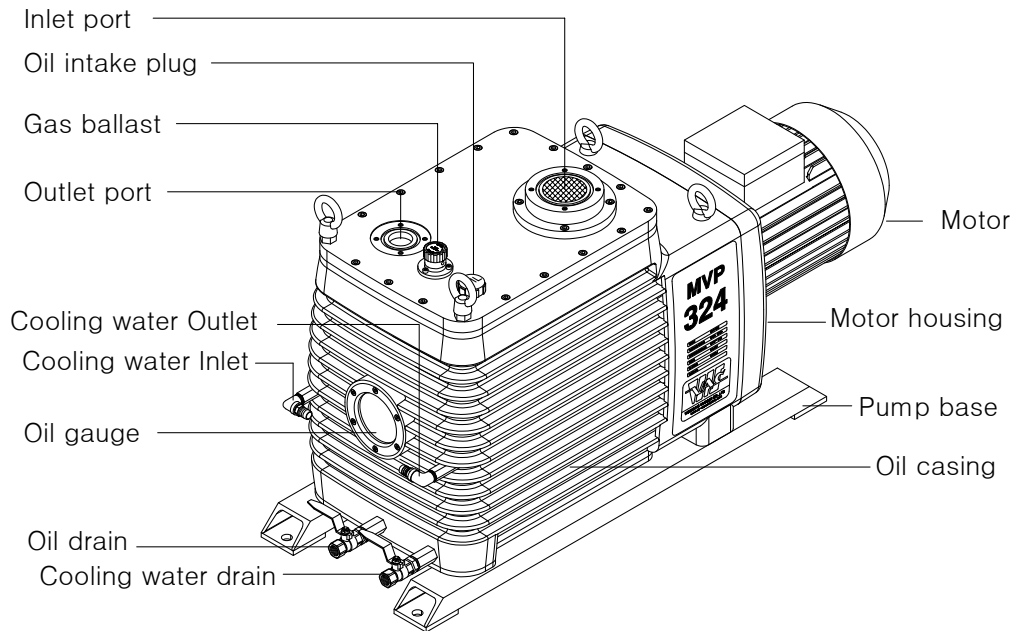

## DESIGN FEATURE

1. 우수한 진공도 및 배기속도
2. 역류방지밸브 시스템이 펌프 정지시 오일 및 오일증기가 진공설비로의 역류방지
3. 국제규격에 따른 흡배기구 (ISO flange)
4. 저소음, 저진동
5. 정압 오일 순환시스템
6. 간단한 가스밸러스트 밸브의 조정
7. 유지보수 및 수리의 용이
8. 공랭식과 수냉식(MVP324/432/540) 모두 사용할 수 있는 구조로 냉각효과가 좋음

1. Excellent ultimate vacuum and pumping speed.
2. Improved oil anti-suckback system to protect the vacuum system in the event of sudden stop.
3. International standard flange.
4. Low noise level and low vibration level.
5. Constant pressure oil circulating system.
6. Convenient gas ballast valve control.
7. Simple repairing and maintenance.
8. Convenient cooling system by air-cooled and water-cooled(MVP324/432/540)

# VANE DUAL STAGE

## TECHNICAL DATA

DESCRIPTION		UNIT	MVP144	MVP216	MVP324	MVP432	MVP540
Displacement Speed	60Hz	m <sup>3</sup> /h	144	216	324	432	540
		L/Min	2400	3600	5400	7200	9000
	50Hz	m <sup>3</sup> /h	120	180	270	360	450
		L/Min	2000	3000	4500	6000	7500
Ultimate pressure	with gas ballast	Torr	5x10 <sup>-3</sup>				
	without gas ballast		5x10 <sup>-4</sup>				
Inlet Port			ISO 63			ISO 100	
Outlet Port			ISO 40			ISO 100	
Motor Power (50Hz/60Hz)		kW	3.7	5.5	7.5	11	15
Rotational speed of pump	60Hz	R.P.M	1750				
	50Hz		1450				
Oil filling		L	11	16	17	28	35
Cooling water(less than 20°C)		L/Min			6	8	8
Noise level(without gas ballast)		dB	75	77	80	82	84
Weight		Kg	172	290	358	584	668

## PUMPING SPEED CURVE

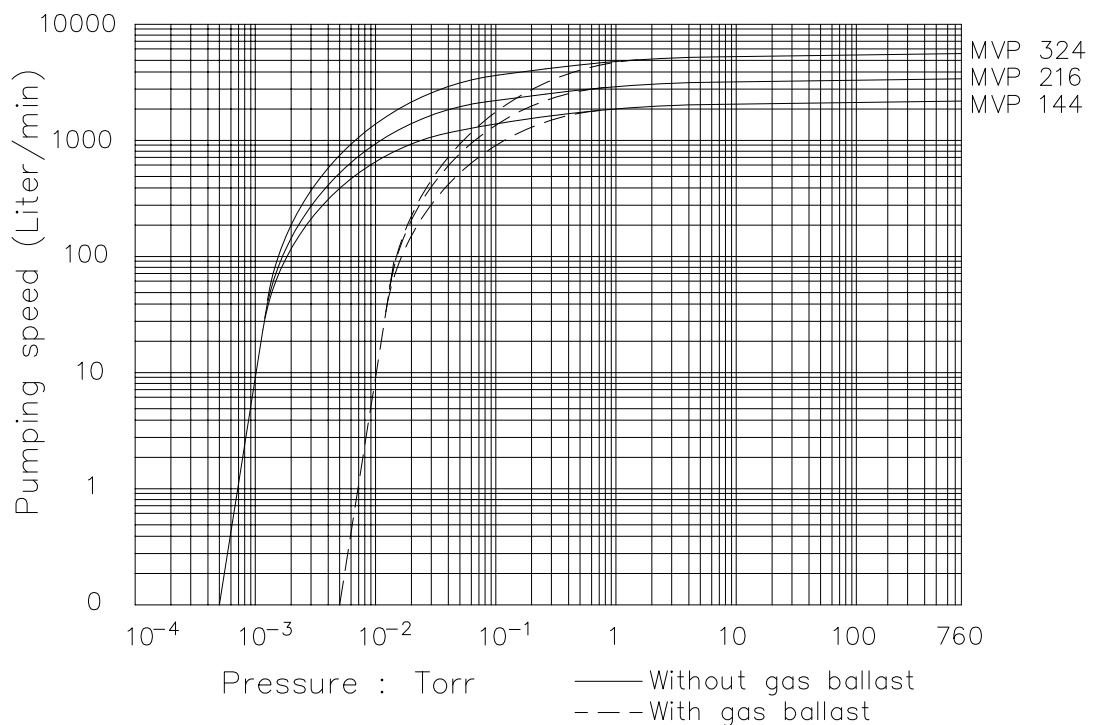

## OUTSIDE DIMENSION

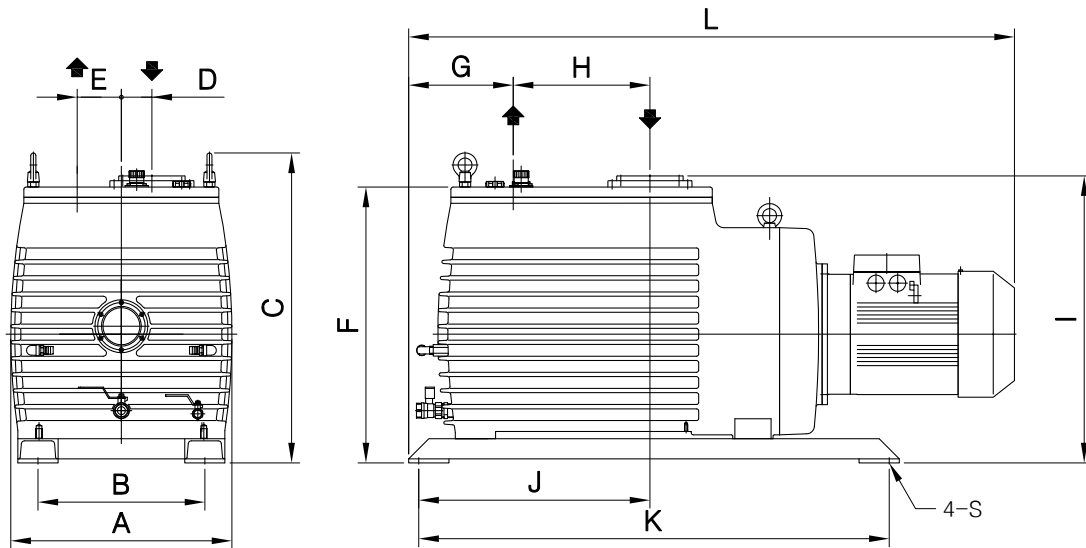

Model	A	B	C	D	E	F	G	H	I	J	K	S	L
MVP144	320	230	501	40	65	414	193	175	465	348	740	Ø14	974
MVP216	400	305	575	58	75	490	195	200	528	375	805	Ø18	1101
MVP324	400	305	645	58	75	560	203	250	598	433	895	Ø18	1179
MVP432	550	415	771	76	110	686	258	225	714	458	1040	Ø18	1377
MVP540	550	415	771	76	110	686	260	340	714	575	1170	Ø18	1507

## APPLICATIONS

포장작업 공정 : 식품진공포장, MAP포장, 성형포장, 블리스터 포장, 튜브포장기 포일운송

가스제거 공정 : 식품생산, 플라스틱 압출, 진공주조, 진공함침, 열처리, 표면코팅, 진공용기

코팅작업 공정 : 금속, 플라스틱, 유리의 코팅 - 라미네이팅 공정 : 태양전지 제품, LCD, 휴대폰 디스플레이

건조작업 공정 : 식품의 동결건조, 분유생산, 슬러지건조, 목재건조, 합성수지 입자 건조

중류작업 공정 : 원유중류, 제약 및 화학분야의 진공 증류

이송작업 공정 : 병원의 흡입이송, 식품의 이송, 플라스틱 제품의 이송, 수분함유 폐기물 이송

고정작업 공정 : 금속, 비금속, 플라스틱 흡착 고정

Packing : food vacuum, MAP, forming, blister and tube packing

Degassing : food industry, plastic injection press, vacuum casting, vacuum impregnation, heat treatment, surface coating

Coating : coating at metal, plastic, glass, etc

Lamination : solar battery products, LCD, mobile phone display

Drying : food freeze-drying, milk powder production, sludge drying, wood drying, synthetic resin particle drying

Distillation : oil distillation, vacuum distillation in chemical and pharmaceutical industry

Transfer : inhale transfer in hospital, food transfer, plastic transfer, water vapour containing waste transfer

Fix : suction mounting



# VANE DUAL STAGE

## WST

---

- WST 180B / 324B



## DETAIL

---



## EXTERNAL PUMP SKETCH

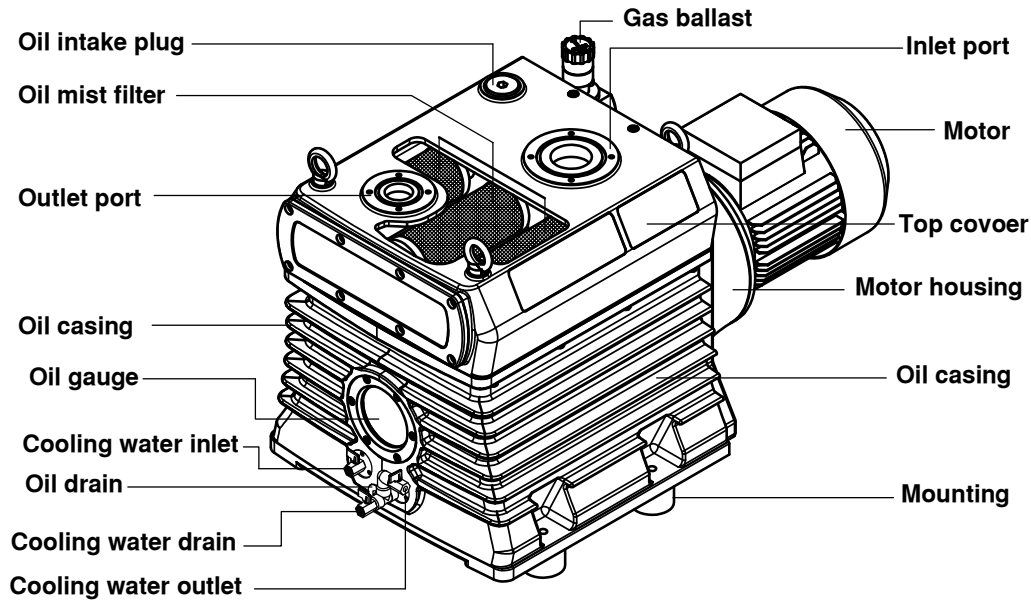

## DESIGN FEATURE

1. 최저 펌프온도를 유지하는 구조로 가혹한 작업공정에 이상적이고 안정된 펌프성능 유지.
2. 우수한 진공도 및 배기속도
3. 역류방지 밸브시스템은 펌프정지시 진공설비로의 오일역류방지
4. 오일미스트트랩은 오일소모를 줄이고 작업장의 환경오염을 방지
5. 정압 오일 순환시스템은 저진공작업에 연속사용이 가능하고 펌프를 보호
6. 국제규격에 따른 흡입구 배기구 사용(ISO flange)
7. 저소음, 저진동
8. 유지보수 및 수리의 용이

1. Stable operating temperature and high performance ideal for rough applications.
2. Excellent ultimate vacuum and pumping speed.
3. Improved anti-suckback system to protect the pump in the event of sudden stop.
4. Oil mist trap reduces oil consumption and prevent pollution.
5. Constant pressured oil circulating system enables continuous operation at low vacuum.
6. International standard flange.(ISO flange)
7. Low noise level and low vibration level.
8. Simple repairing and maintenance.

# VANE DUAL STAGE

## TECHNICAL DATA

DESCRIPTION		UNIT	WST-180B	WST-324B
Displacement Speed	60Hz	m <sup>3</sup> /h	180	324
		L/Min	3000	5400
	50Hz	m <sup>3</sup> /h	150	270
		L/Min	2500	4500
Ultimate pressure with gas ballast		Torr	5 x 10 <sup>-3</sup>	
Ultimate pressure without gas ballast			5 x 10 <sup>-4</sup>	
Inlet Port			ISO 63	
Outlet Port			ISO 63	
Motor Power (50Hz/60Hz)		kW	3.7	7.5
Rotational speed of pump	60Hz	R.P.M	1750	
	50Hz		1450	
Oil filling		L	15	20
Cooling water(less than 20°C)		L/Min	3	4
Weight		Kg	194	280

## PUMPING SPEED CURVE

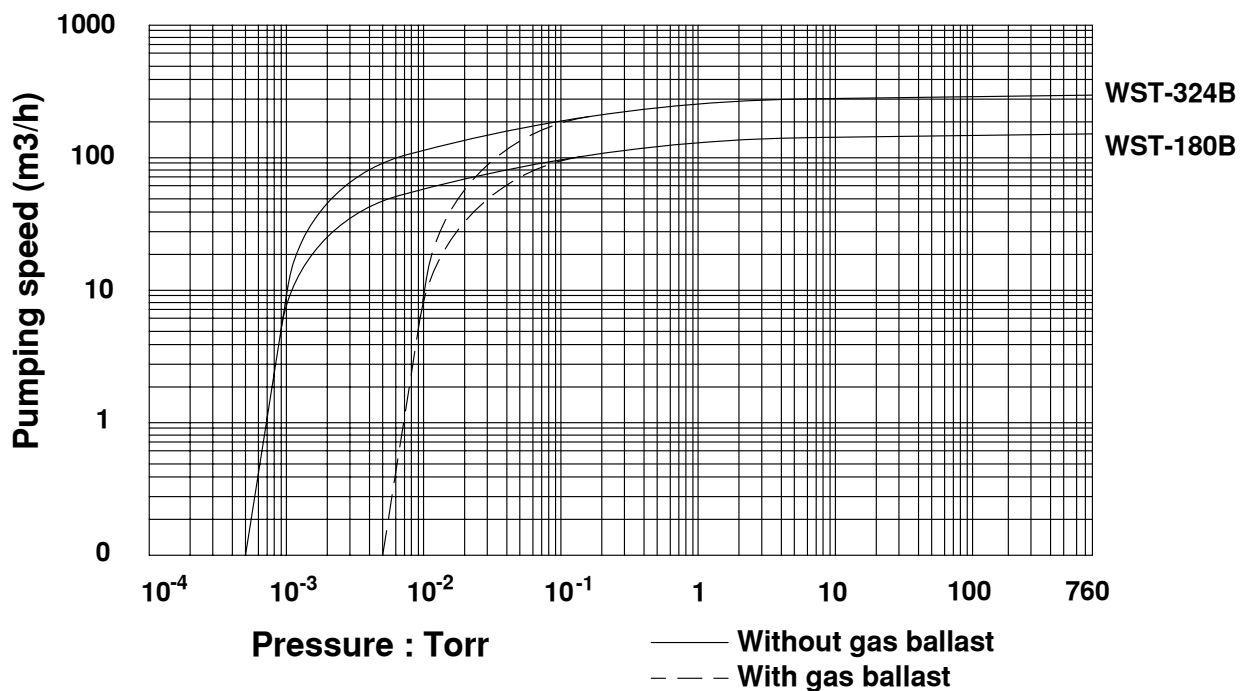

## OUTSIDE DIMENSION

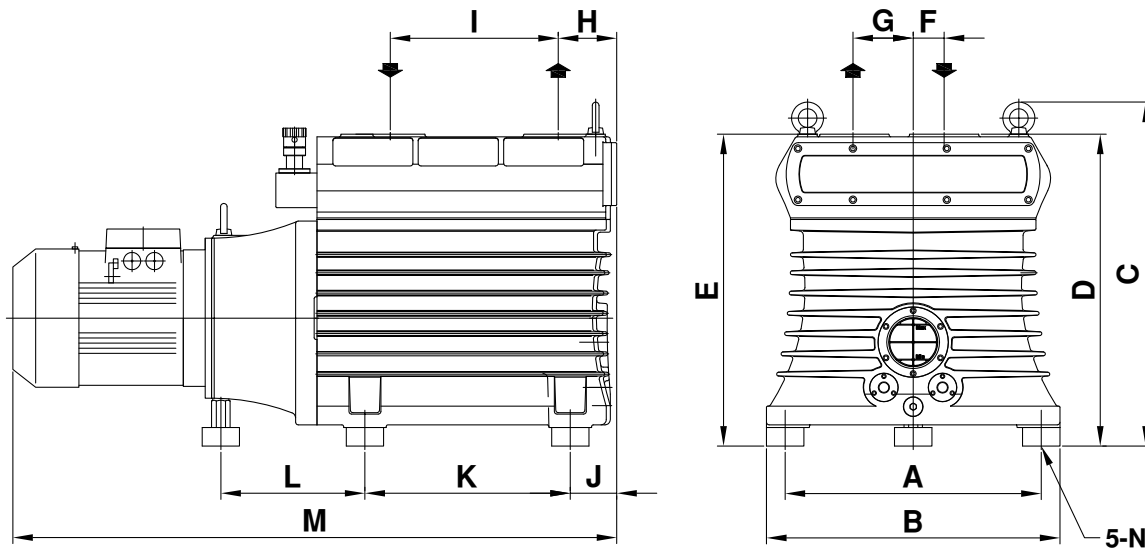

Model	A	B	C	D	E	F	G	H	I	J	K	L	M	N	O	P
WST-180B	938	460	558	50	57.5	505	505	113	225	125	200	200	134	210	249	M10
WST-324B	1132	550	645	58	113	585	585	110	315	137.5	240	240	87	385	270	M10

## APPLICATIONS

포장작업 공정 : 식품진공포장, MAP포장, 성형포장, 블리스터 포장, 튜브포장기 포일운송

가스제거 공정 : 식품생산, 플라스틱 압출, 진공주조, 진공함침, 열처리, 표면코팅, 진공용기

코팅작업 공정 : 금속, 플라스틱, 유리의 코팅 - 라미네이팅 공정 : 태양전지 제품, LCD, 휴대폰 디스플레이

건조작업 공정 : 식품의 동결건조, 분유생산, 슬러지건조, 목재건조, 합성수지 입자 건조

중류작업 공정 : 원유중류, 제약 및 화학분야의 진공 중류

이송작업 공정 : 병원의 흡입이송, 식품의 이송, 플라스틱 제품의 이송, 수분함유 폐기물 이송

고정작업 공정 : 금속, 비금속, 플라스틱 흡착 고정

Packing : food vacuum, MAP, forming, blister and tube packing

Degassing : food industry, plastic injection press, vacuum casting, vacuum impregnation, heat treatment, surface coating

Coating : coating at metal, plastic, glass, etc

Lamination : solar battery products, LCD, mobile phone display

Drying : food freeze-drying, milk powder production, sludge drying, wood drying, synthetic resin particle drying

Distillation : oil distillation, vacuum distillation in chemical and pharmaceutical industry

Transfer : inhale transfer in hospital, food transfer, plastic transfer, water vapour containing waste transfer

Fix : suction mounting

# VANE DUAL STAGE

## WSVP

- WSVP 2120 / 2130 / 2150



## DETAIL





## EXTERNAL PUMP SKETCH

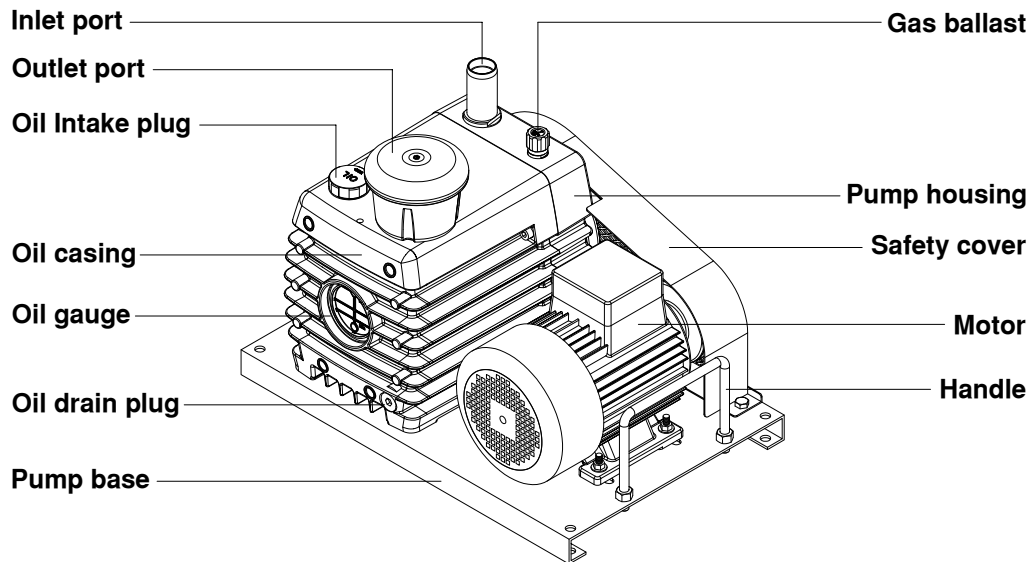

## DESIGN FEATURE

1. 최저 펌프온도를 유지하는 구조로 가혹한 작업공정에 이상적이고 안정된 펌프성능 유지.
2. 우수한 진공도 및 배기속도
3. 간단한 가스밸러스트 밸브 조정으로 응축성 가스의 작업공정에 용이
4. 콤팩트한 설계
5. 저소음 및 저진동
6. 간단한 유지보수 및 펌프 수리의 용이

1. Stable operating temperature and high performance ideal for rough applications.
2. Excellent ultimate vacuum and pumping speed.
3. Easy control of gas ballast valve.
4. Simple compact design.
5. Low vibration level and low noise level.
6. Easy maintenance and repairing.

# VANE DUAL STAGE

## TECHNICAL DATA

DESCRIPTION		UNIT	WSVP2120	WSVP2130	WSVP2150
Displacement Speed	60Hz	m <sup>3</sup> /h	12	18	30
		L/Min	200	300	500
Ultimate pressure with gas ballast (I)		Torr	5 x 10 <sup>-2</sup>		
Ultimate pressure without gas ballast(C)			5 x 10 <sup>-4</sup>		
Inlet Port			Ø32	Ø32	Ø46
Outlet Port			M35x1.5	M35x1.5	M50x1.5
Motor Power (50Hz/60Hz)		kW	0.4	0.75	0.75
Rotational speed of pump	60Hz	R.P.M	900		
Oil filling		L	1.8	2	4.0
V-belt		Size/Q'ty	A34"/1	A34"/1	A41"/2
Weight		Kg	23(37)	26(43)	46(71)

## PUMPING SPEED CURVE

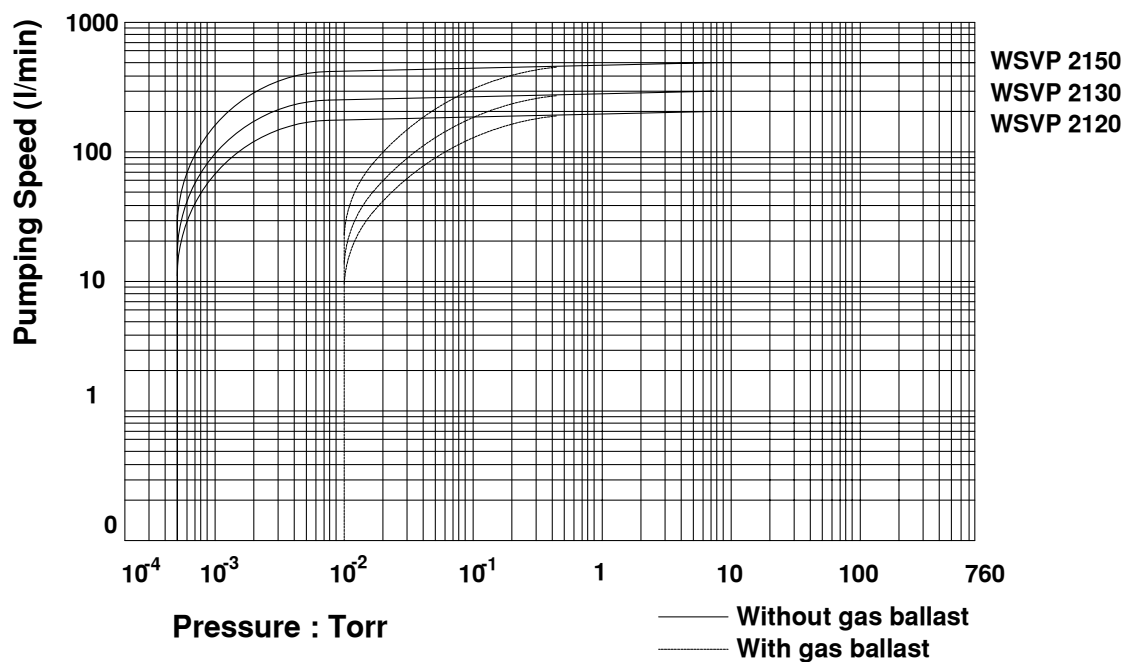

## OUTSIDE DIMENSION

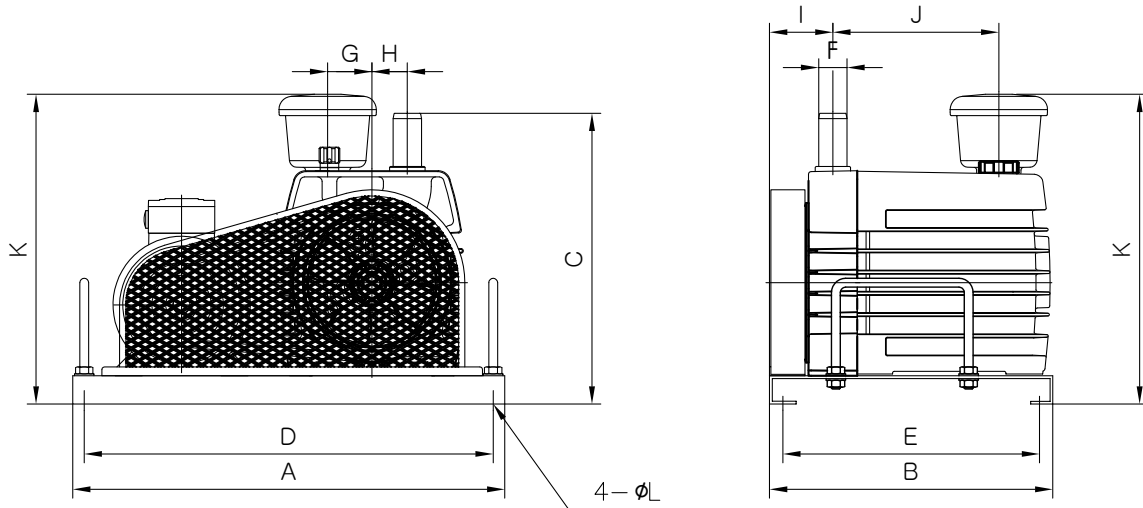

Model	A	B	C	D	E	F	G	H	I	J	K	L
WSVP2120	488	285	329	462	255	Ø32	50	40	71.5	157.50	350	Ø11
WSVP2130	488	320	329	462	290	Ø32	50	40	71.5	187.50	385	Ø11
WSVP2150	580	395	417	550	365	Ø46	50	40	79.5	230	454	Ø11

## APPLICATIONS

포장작업 공정 : 식품진공포장, MAP포장, 성형포장, 블리스터 포장, 튜브포장기 포일운송

가스제거 공정 : 식품생산, 플라스틱 압출, 진공주조, 진공함침, 열처리, 표면코팅, 진공용기

코팅작업 공정 : 금속, 플라스틱, 유리의 코팅 - 라미네이팅 공정 : 태양전지 제품, LCD, 휴대폰 디스플레이

건조작업 공정 : 식품의 동결건조, 분유생산, 슬러지건조, 목재건조, 합성수지 입자 건조

증류작업 공정 : 원유증류, 제약 및 화학분야의 진공 증류

이송작업 공정 : 병원의 흡입이송, 식품의 이송, 플라스틱 제품의 이송, 수분함유 폐기물 이송

고정작업 공정 : 금속, 비금속, 플라스틱 흡착 고정

Packing : food vacuum, MAP, forming, blister and tube packing

Degassing : food industry, plastic injection press, vacuum casting, vacuum impregnation, heat treatment, surface coating

Coating : coating at metal, plastic, glass, etc

Lamination : solar battery products, LCD, mobile phone display

Drying : food freeze-drying, milk powder production, sludge drying, wood drying, synthetic resin particle drying

Distillation : oil distillation, vacuum distillation in chemical and pharmaceutical industry

Transfer : inhale transfer in hospital, food transfer, plastic transfer, water vapour containing waste transfer

Fix : suction mounting

# OIL ROTARY-PISTON

## WSSR-V

- WSSR V1.5K / V2.5K / V4.8K / V7.5K



## DETAIL



## EXTERNAL PUMP SKETCH

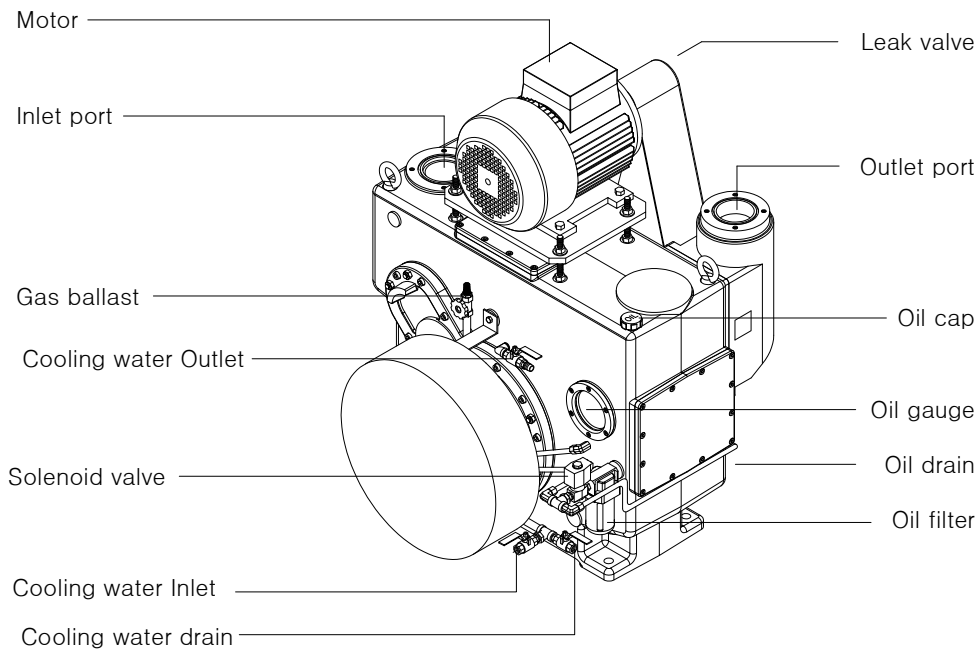

## DESIGN FEATURE

1. 우수한 진공 및 배기속도
2. 간단한 가스밸러스트 밸브 조정으로 응축성 가스의 작업공정에 용이
3. 컴팩트한 설계
4. 공랭식(적용모델 : WSSR-V1.5K)과 수랭식 냉각방법 적용으로 안정적인 연속운전
5. 저소음 및 저진동
6. 흡입구, 배기구 진공용 플랜지(KSB-1540)규격 적용
7. 간단한 유지보수 및 펌프 수리의 용이

1. Excellent ultimate vacuum and pumping speed.
2. Easy control of gas ballast valve.
3. Simple compact design.
4. Efficient cooling system, air-cooling for WSSR-V15K and water-cooling for the rest, for continuous operation.
5. Low vibration level and low noise level.
6. Vacuum flange (KSB-1540) is used for inlet and outlet of pump.
7. Easy maintenance and repairing.

## TECHNICAL DATA

DESCRIPTION	UNIT	WSSR-V1.5K	WSSR-V2.5K	WSSR-V4.8K	WSSR-V7.5K
Displacement Speed	L/Min	1500	2500	4800	7500
Ultimate pressure	Torr	$5 \times 10^{-3}$			
Inlet Port		VG50	VG80	VG80	VG100
Outlet Port		VG50		VG65	VG100
Motor Power	kW	2.2	3.7	7.5	11
Rotational speed of pump	R.P.M	410			380
Oil filling	L	5	8	17	29
V-belt	Size/Q'ty	3V-590/3	3V-640/3	3V-800/4	3V-950/5
Weight	Kg	236	324	555	791
Cooling water	L		5	5	7

## PUMPING SPEED CURVE

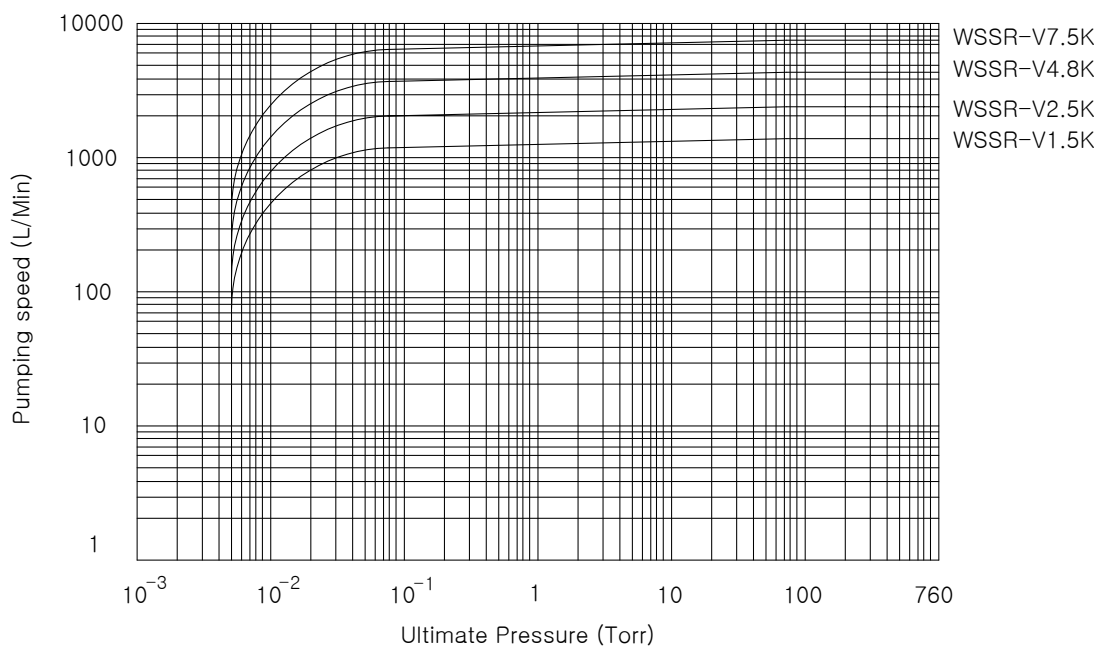



## OUTSIDE DIMENSION

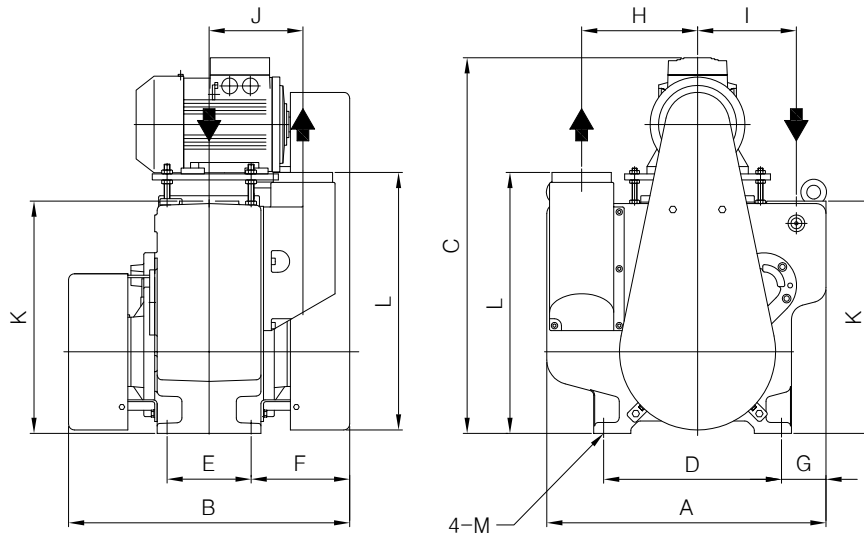

Model	A	B	C	D	E	F	G	H	I	J	K	L	M
WSSR-V1.5K	560	575	760	360	170.0	206	90	235	200	190	470	530	Ø14
WSSR-V2.5K	670	605	815	450	180.0	216	95	276.5	220	205	515	569	Ø20
WSSR-V4.8K	805	740	1035	1035	230.0	260	105	326	290	250	675	750	Ø20
WSSR-V7.5K	900	826	1190	1190	280	279	125	364	317.5	300.0	765	857	Ø20

## APPLICATIONS

포장작업 공정 : 식품진공포장, MAP포장, 성형포장, 블리스터 포장, 튜브포장기 포일운송

가스제거 공정 : 식품생산, 플라스틱 압출, 진공주조, 진공함침, 열처리, 표면코팅, 진공용기

코팅작업 공정 : 금속, 플라스틱, 유리의 코팅 - 라미네이팅 공정 : 태양전지 제품, LCD, 휴대폰 디스플레이

건조작업 공정 : 식품의 동결건조, 분유생산, 슬러지건조, 목재건조, 합성수지 입자 건조

증류작업 공정 : 원유증류, 제약 및 화학분야의 진공 증류

이송작업 공정 : 병원의 흡입이송, 식품의 이송, 플라스틱 제품의 이송, 수분함유 폐기물 이송

고정작업 공정 : 금속, 비금속, 플라스틱 흡착 고정

Packing : food vacuum, MAP, forming, blister and tube packing

Degassing : food industry, plastic injection press, vacuum casting, vacuum impregnation, heat treatment, surface coating

Coating : coating at metal, plastic, glass, etc

Lamination : solar battery products, LCD, mobile phone display

Drying : food freeze-drying, milk powder production, sludge drying, wood drying, synthetic resin particle drying

Distillation : oil distillation, vacuum distillation in chemical and pharmaceutical industry

Transfer : inhale transfer in hospital, food transfer, plastic transfer, water vapour containing waste transfer

Fix : suction mounting

**DRY SCREW PUMP**

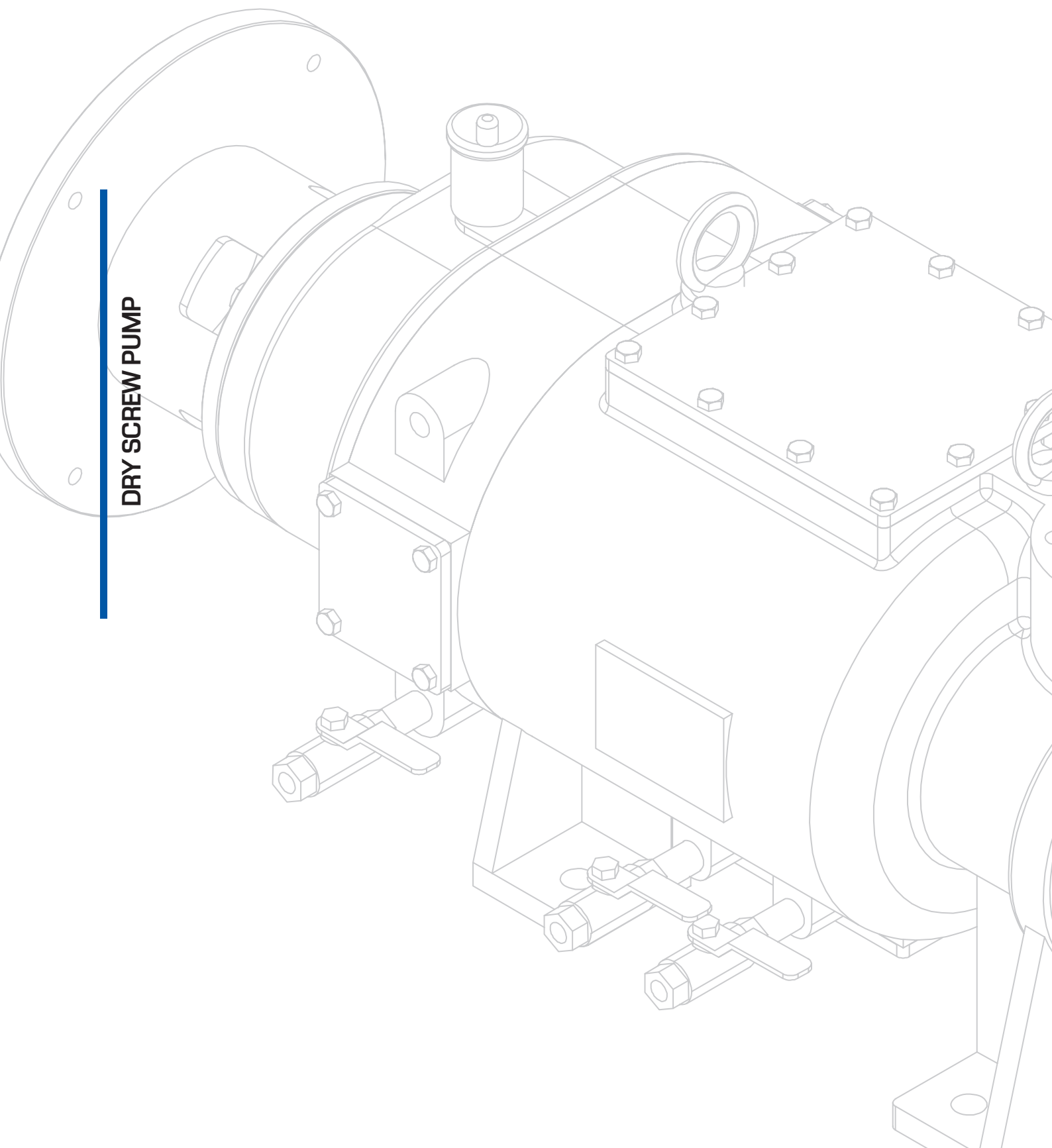

# DRY Screw Pump

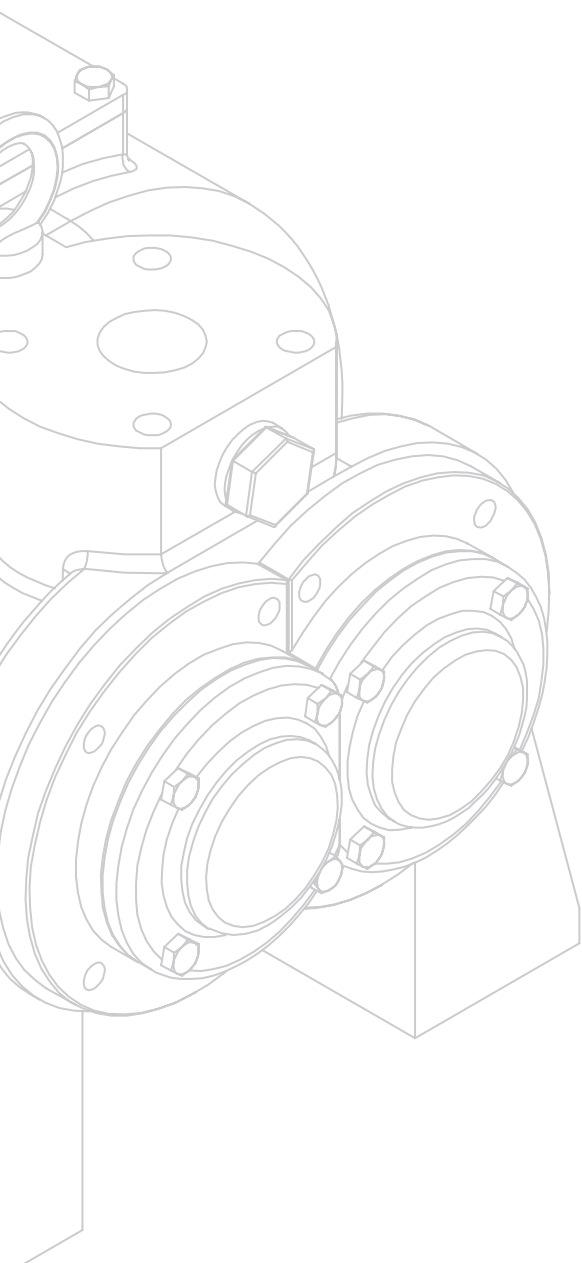

## **TDP**

- TDP 150 / 250 / 400  
800 / 1500

---

## **MDP-S**

- MDP 150S / 300S / 400S  
800S / 1000S / 1500S

---

## **MDP-B**

- MDP 300B / 400B /  
600B / 800B

# DRY SCREW PUMP

## TDP

---

- TDP 150 / 250 / 400  
800 / 1500



## DETAIL

---



## EXTERNAL PUMP SKETCH

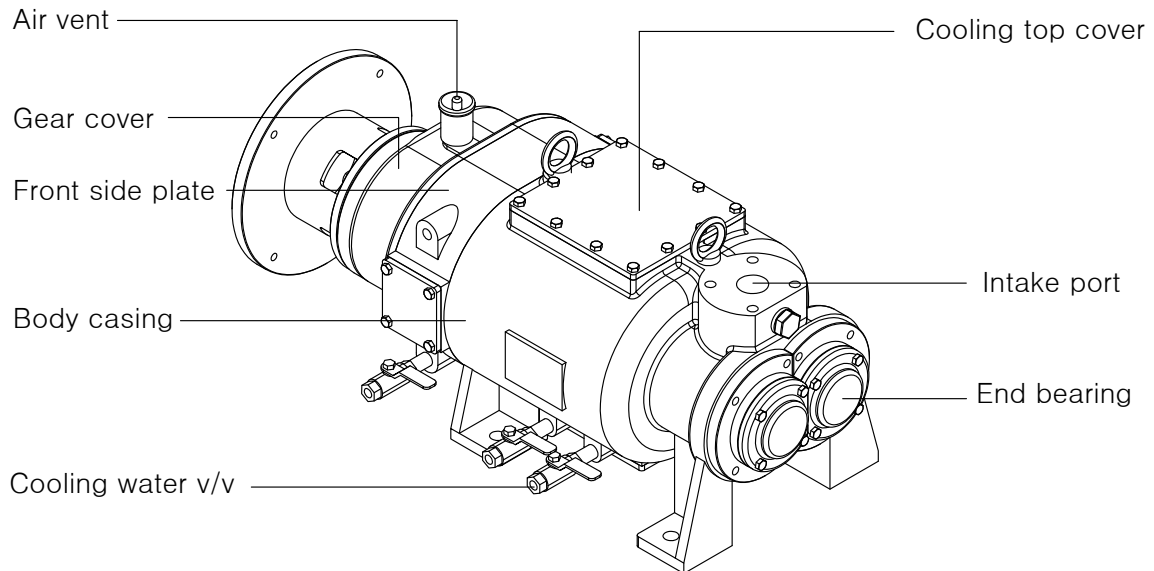

## DESIGN FEATURE

1. 오일이나 물을 사용하지 않아 폐수, 폐유 발생 문제가 없다
2. 구조가 간단하여 내구성이 탁월하고 유지보수가 쉽다.
3. Screw에 의한 건식타입으로 냉각수 또는 공정중의 온도변화에도 진공도 변화가 없다.
4. 가스 접촉부위 screw casing에 특수 코팅이 되어 부식성에 강하다.
5. 공정 중 vapour의 외부 누출이 없으므로 작업환경이 깨끗하다.
6. 고속회전용 정밀 1급 Timing Gear와 Bearing 채택으로 소음의 최소화, screw rotor는 computer dynamic balance로 진동이 적다.
7. Pump를 C" flange type으로 motor와 체결하여 진동 및 운전에 안정적으로 사용할 수 있도록 설계되었다.

1. There is no problem of polluted water and oil, because the oil and water is not to be used.
2. Its easy to maintenance because of simple structure with excellent durability.
3. It is dry type with screw option, and there is no change in the temperature of vacuum even if the temperature change of cooling water in process.
4. Gas contact areas have special coating on the screw casing that made it strong against corrosion.
5. The working environment is clean because there is no external leakage of vapour during the process.
6. Because of the high class timing gear and bearing with high speed rotation, which helps to reduce the noise.  
Screw rotor is computer dynamic balanced with low vibration.
7. This pump as c" flange type, which is designed to be used stably for vibration and operation.

# DRY SCREW PUMP

## TECHNICAL DATA

DESCRIPTION	UNIT	TDP150	TDP250	TDP400	TDP800	TDP1500
Maximum pumping speed(50Hz/60Hz)	m <sup>3</sup> /h	120/150	175/250	335/400	720/800	1350/1500
Ultimate pressure	Torr	0.1	0.05	0.05	0.05	0.05
	mbar	0.133	0.067	0.067	0.067	0.067
	Pa	13.3	6.7	6.7	6.7	6.7
Suction diameter(inlet)		40	50	65	100	125
Discharge diameter(outlet)		40	40	50	65	80
Motor Power (50Hz/60Hz)	kW	3.7/5.5	5.5/7.5	11/15	18.5/22	37
Rotational speed of pump(50Hz/60Hz)	R.P.M	2900/3500				2900
Cooling water	L	7	10	15	18	30
Weight	Kg	210	280	420	590	950

## PUMPING SPEED CURVE

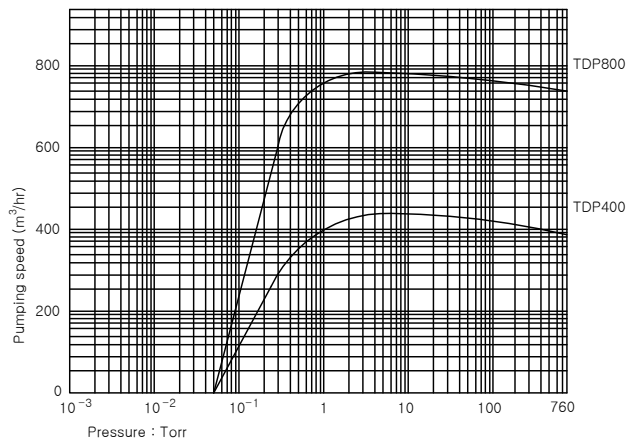
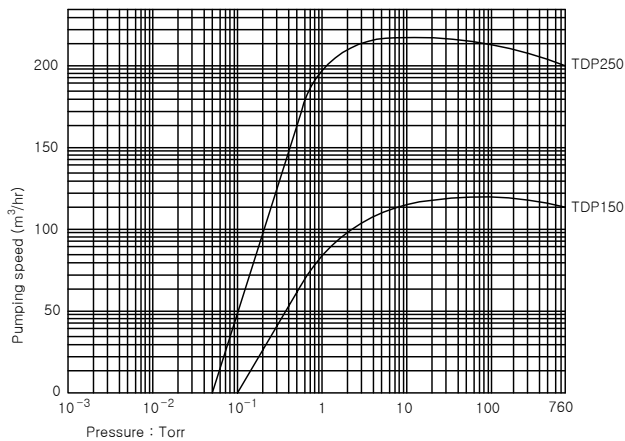



## OUTSIDE DIMENSION

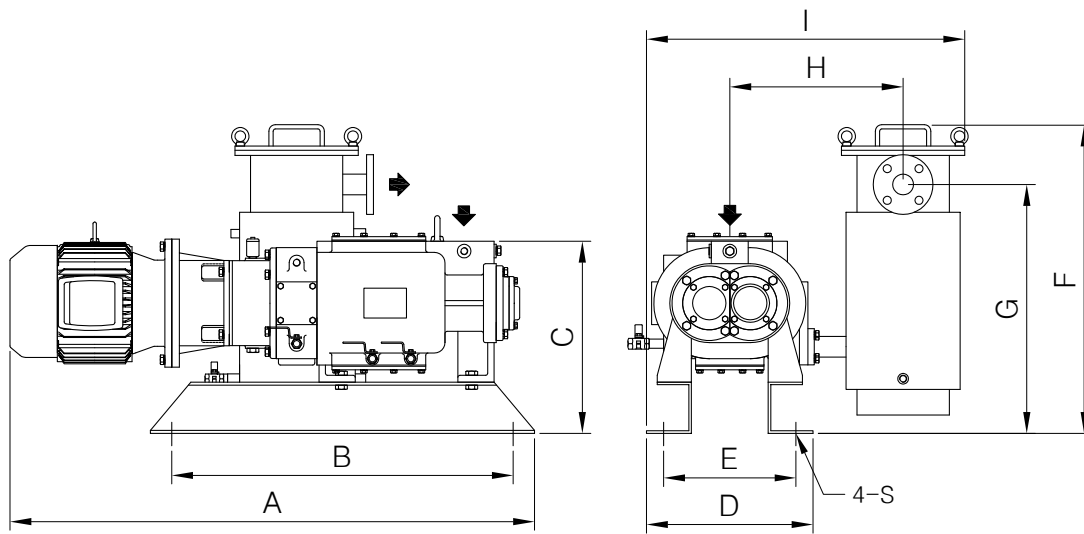

Model	A	B	C	D	E	F	G
TDP150	450	583	723	800	1230	310	790
TDP250	450	583	723	800	1260	310	790
TDP400	550	655	795	1150	1450	525	960
TDP800	588	780	927	1420	1685	695	1085
TDP1500	767	1250	1390	1700	2100	900	1300

## APPLICATIONS

포장작업 공정 : 식품진공포장, MAP포장, 성형포장, 블리스터 포장, 튜브포장기 포일운송

가스제거 공정 : 식품생산, 플라스틱 압출, 진공주조, 진공함침, 열처리, 표면코팅, 진공용기

코팅작업 공정 : 금속, 플라스틱, 유리의 코팅 - 라미네이팅 공정 : 태양전지 제품, LCD, 휴대폰 디스플레이

건조작업 공정 : 식품의 동결건조, 분유생산, 슬러지건조, 목재건조, 합성수지 입자 건조

증류작업 공정 : 원유증류, 제약 및 화학분야의 진공 증류

이송작업 공정 : 병원의 흡입이송, 식품의 이송, 플라스틱 제품의 이송, 수분함유 폐기물 이송

고정작업 공정 : 금속, 비금속, 플라스틱 흡착 고정

Packing : food vacuum, MAP, forming, blister and tube packing

Degassing : food industry, plastic injection press, vacuum casting, vacuum impregnation, heat treatment, surface coating

Coating : coating at metal, plastic, glass, etc

Lamination : solar battery products, LCD, mobile phone display

Drying : food freeze-drying, milk powder production, sludge drying, wood drying, synthetic resin particle drying

Distillation : oil distillation, vacuum distillation in chemical and pharmaceutical industry

Transfer : inhale transfer in hospital, food transfer, plastic transfer, water vapour containing waste transfer

Fix : suction mounting

# DRY SCREW PUMP

## MDP-S

- MDP 150S / 300S / 400S  
800S / 1500S



## DETAIL

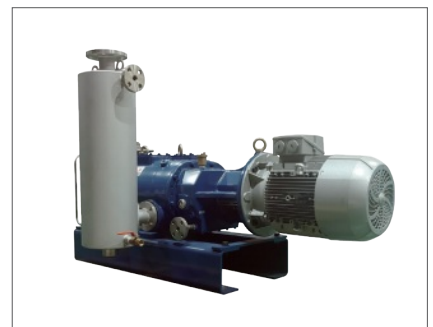

## EXTERNAL PUMP SKETCH

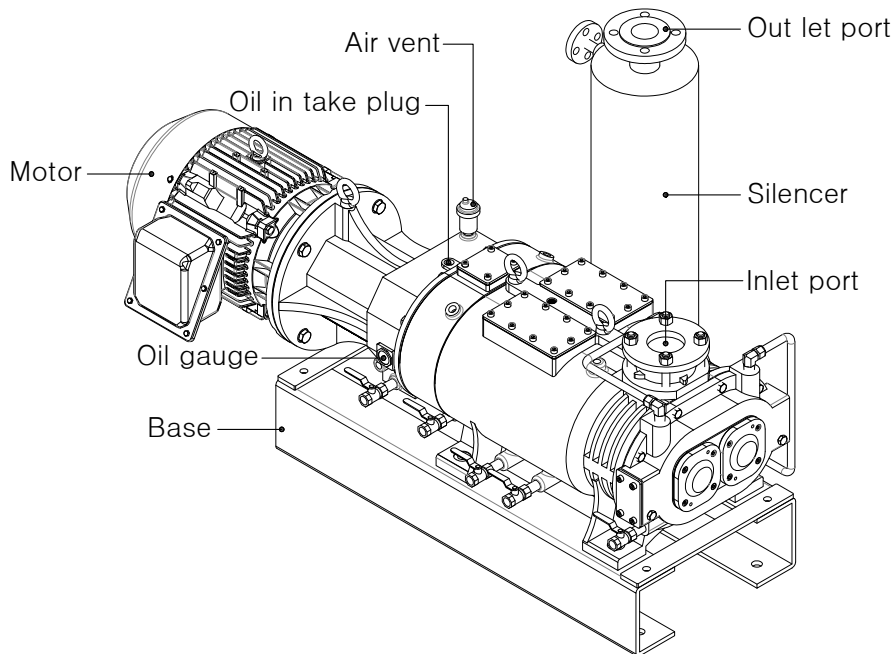

## DESIGN FEATURE

1. 최적의 공차로 펌프단독으로 지속적인 고진공이 가능하다
2. 가변피치 설계로 전력을 30% 절감할 수 있다.
3. 코팅을 적용하여 내식성(부식 방지)을 갖추었다.
4. 공정에 맞추어 코팅의 종류나 도금이 가능하다
5. 최적의 펌프 내부 온도를 유지한다.
6. 공정 가스로 인한 오염이 없다.
7. 오일이나 물을 사용하지 않아, 유지보수비용이 절감된다.
8. 용제를 배기로 바로 회수 할 수 있다.

1. Optimized clearance and continuous compression ensures high vacuum degree with a single pump.
2. 30% power saving by the variable pitch screw design.
3. Coating material provides excellent corrosion resistance.
4. Process specific coatings or platings available.
5. Maintains optimum pump-inside temperature.
6. No Contamination of Process Stream.
7. No oil or water is used, reducing maintenance costs.
8. Immediate Solvent Recovery at Pump Exhaust.

# DRY SCREW PUMP

## TECHNICAL DATA

DESCRIPTION	UNIT	MDP150S	MDP300S	MDP400S	MDP800S	MDP1000S	MDP1500S
Maximum pumping speed (50/60Hz)	m <sup>3</sup> /hr	110/130	250/300	330/400	660/800	1830/1000	1250/1500
Ultimate pressure(60Hz)	torr	0.007	0.007	0.007	0.007	0.01	0.01
	mbar	0.009	0.009	0.009	0.009	0.013	0.013
		1	1	1	1	1.3	1.3
Suction Diameter (inlet)		40A	50A	65A	100A	100A	125A
Discharge Diameter (outlet)		40A	40A	50A	65A	65A	80A
Motor power(60Hz)	kW	3.7	7.5	11	15	18.5	37
Rotational Speed(50/60Hz)	r.p.m	2900/3500	2900/3500	2900/3500	2900/3500	2900/3500	2900/3500
Cooling water supply	L/Min	5~10	10~15	15~20	15~20	20~25	36~40
Weight (pump only)	kg	190	300	380	600	680	900

## PUMPING SPEED CURVE

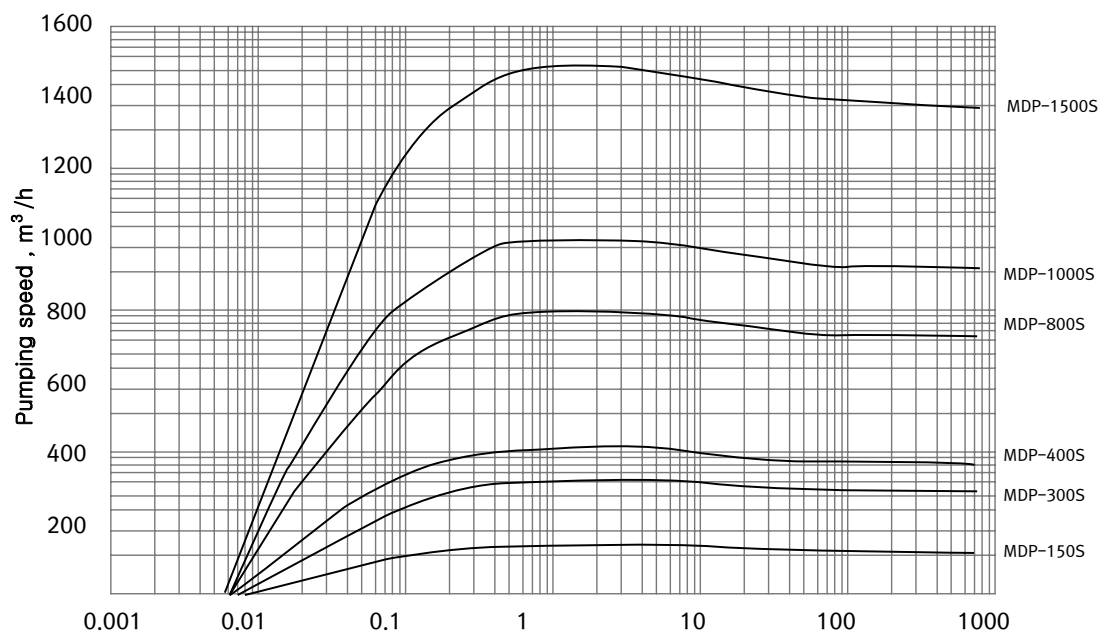

## OUTSIDE DIMENSION

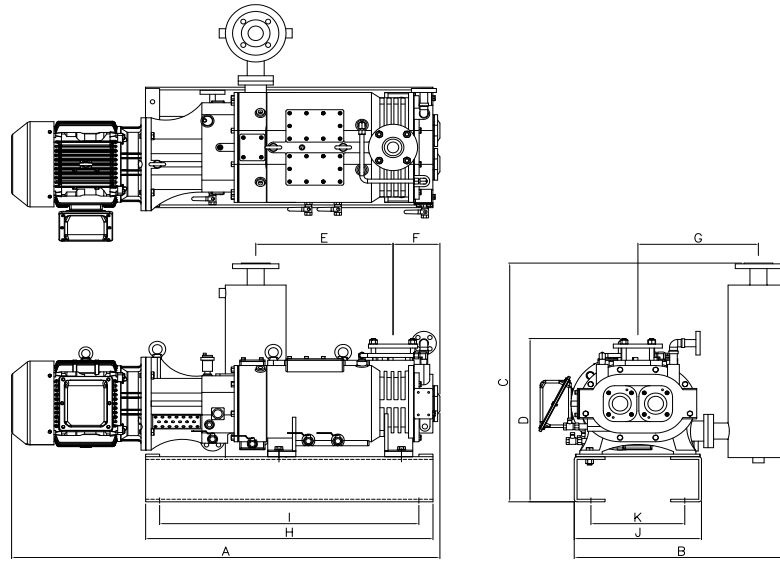

Model	A	B	C	D	E	F	G	H	I	J	K
MDP150S	1000	548	748	436	287	108	320	650	550	341	245
MDP300S	1321	742	915	600	439	154	425	935	835	418	300
MDP400S	1528	765	915	615	490	167	430	1025	925	454	335
MDP800S	1704	907	1052	669	598	203	517	1100	900	512	372
MDP1000S	1625	907	1052	669	521	203	517	1022	822	512	372
MDP1500S	2121	1010	1097	851	593	246	570	1700	4600	670	460

## APPLICATIONS

포장작업 공정 : 식품진공포장, MAP포장, 성형포장, 블리스터 포장, 튜브포장기 포일운송

가스제거 공정 : 식품생산, 플라스틱 압출, 진공주조, 진공함침, 열처리, 표면코팅, 진공용기

코팅작업 공정 : 금속, 플라스틱, 유리의 코팅 - 라미네이팅 공정 : 태양전지 제품, LCD, 휴대폰 디스플레이

건조작업 공정 : 식품의 동결건조, 분유생산, 슬러지건조, 목재건조, 합성수지 입자 건조

증류작업 공정 : 원유증류, 제약 및 화학분야의 진공 증류

이송작업 공정 : 병원의 흡입이송, 식품의 이송, 플라스틱 제품의 이송, 수분함유 폐기물 이송

고정작업 공정 : 금속, 비금속, 플라스틱 흡착 고정

Packing : food vacuum, MAP, forming, blister and tube packing

Degassing : food industry, plastic injection press, vacuum casting, vacuum impregnation, heat treatment, surface coating

Coating : coating at metal, plastic, glass, etc

Lamination : solar battery products, LCD, mobile phone display

Drying : food freeze-drying, milk powder production, sludge drying, wood drying, synthetic resin particle drying

Distillation : oil distillation, vacuum distillation in chemical and pharmaceutical industry

Transfer : inhale transfer in hospital, food transfer, plastic transfer, water vapour containing waste transfer

Fix : suction mounting

# DRY SCREW PUMP

## MDP-B

- MDP 300B / 400B / 600B / 800B



## DETAIL

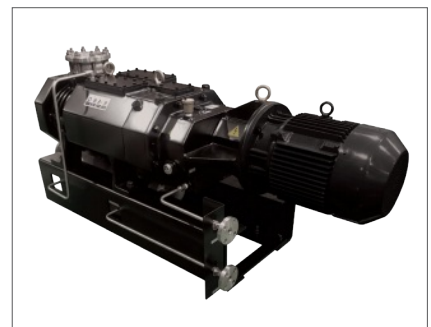



## EXTERNAL PUMP SKETCH

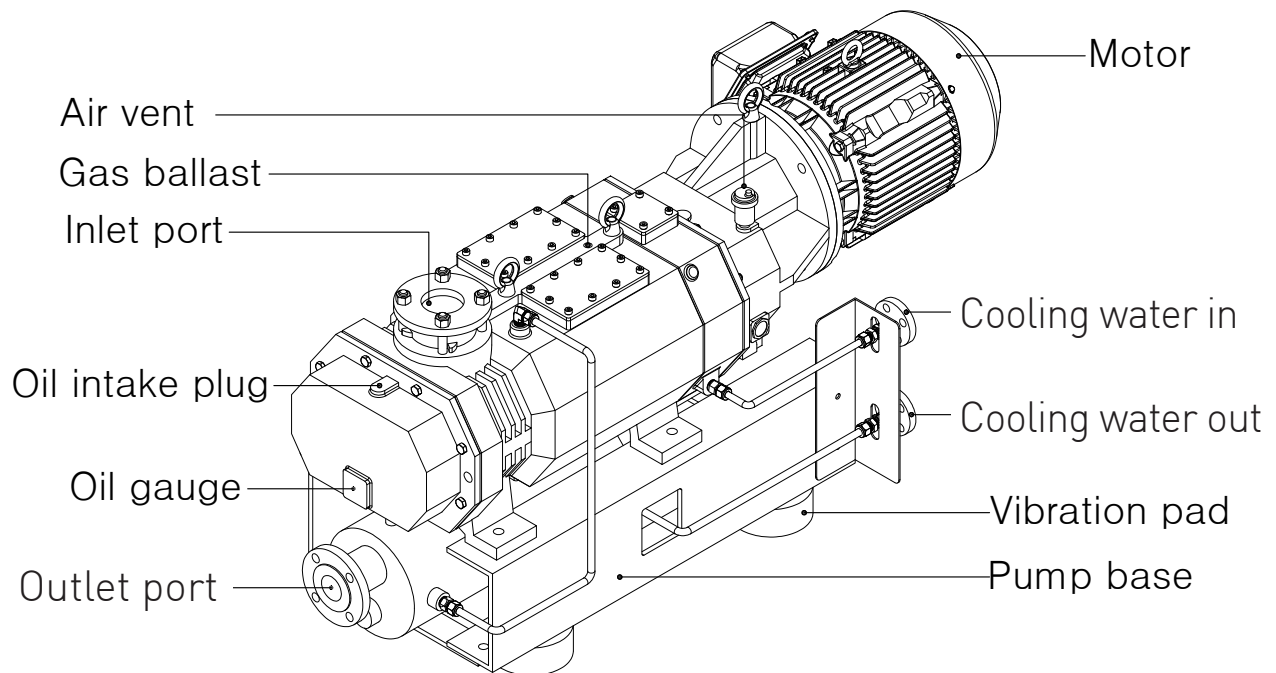

## DESIGN FEATURE

- |   |  |
|---|--|
| <ol style="list-style-type: none"> <li>1. 최적의 공차로 펌프단독으로 지속적인 고진공이 가능하다.</li> <li>3. 코팅을 적용하여 내식성(부식 방지)을 갖추었다.</li> <li>5. 최적의 펌프 내부 온도를 유지한다.</li> <li>6. 공정 가스로 인한 오염이 없다.</li> <li>7. 오일이나 물을 사용하지 않아, 유지보수비용이 절감된다.</li> <li>8. 용제를 배기로 바로 회수 할 수 있다.</li> <li>9. 응축 공정에서 100% 프로세스를 배출하여 잔류 공정액이 남아 있지 않아 코팅 내구성 증대된다.</li> <li>10. 하부 배출방식으로 공간 효율성이 좋다</li> <li>11. 액체 및 파우더 처리 능력이 뛰어나다</li> </ol> | <ol style="list-style-type: none"> <li>2. 가변피치 설계로 전력을 30% 절감할 수 있다.</li> <li>4. 공정에 맞추어 코팅의 종류나 도금이 가능하다</li> </ol> |
|---|--|
- 
1. Optimized clearance and continuous compression ensures high vacuum degree with a single pump.
  2. 30% power saving by the variable pitch screw design.
  3. Coating material provides excellent corrosion resistance.
  4. Process specific coatings or platings available.
  5. Maintains optimum pump-inside temperature.
  6. No Contamination of Process Stream.
  7. No oil or water is used, reducing maintenance costs.
  8. Immediate Solvent Recovery at Pump Exhaust.
  9. Because 100% of the process is discharged from the vacuum.
  10. Space efficiency is good with bottom discharge type.
  11. Superior Liquid and powder handling ability.

# DRY SCREW PUMP

## TECHNICAL DATA

DESCRIPTION	UNIT	MDP300B	MDP400B	MDP600B	MDP800B
Maximum pumping speed(50/60Hz)	m <sup>3</sup> /hr	250/300	330/400	500/600	660/800
Ultimate pressure(60Hz)	Torr	0.0075	0.0075	0.010	0.0075
	mbar	0.009	0.009	0.013	0.009
	Pa	1	1	1.3	1
Suction Diameter (inlet)	mm	50A	65A	100A	100A
Discharge Diameter (outlet)	mm	40A	50A	65A	65A
Motor power	kW	7.5	11	15	18.5
Rotational Speed(50Hz/60Hz)	rpm	2,900/3,500	2,900/3,500	2,900/3,500	2,900/3,500
Cooling water supply	Liter/min	10~15	15~20	15~20	15~20
Weight(Pump only)	kg	300	380	480	600

## PUMPING SPEED CURVE

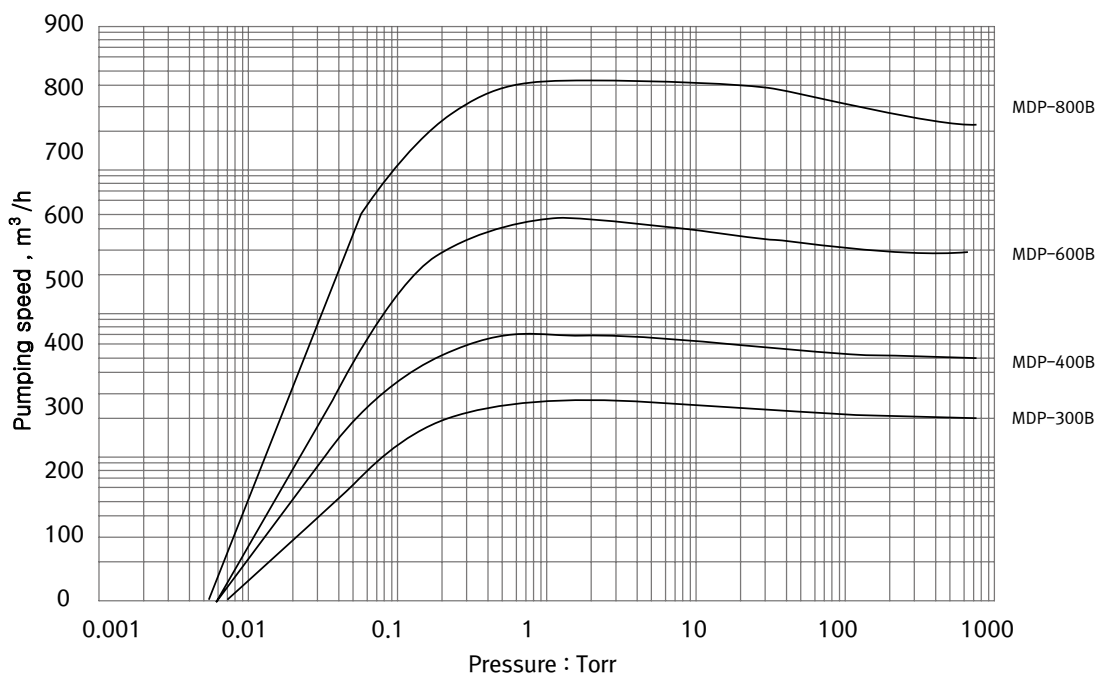

## OUTSIDE DIMENSION

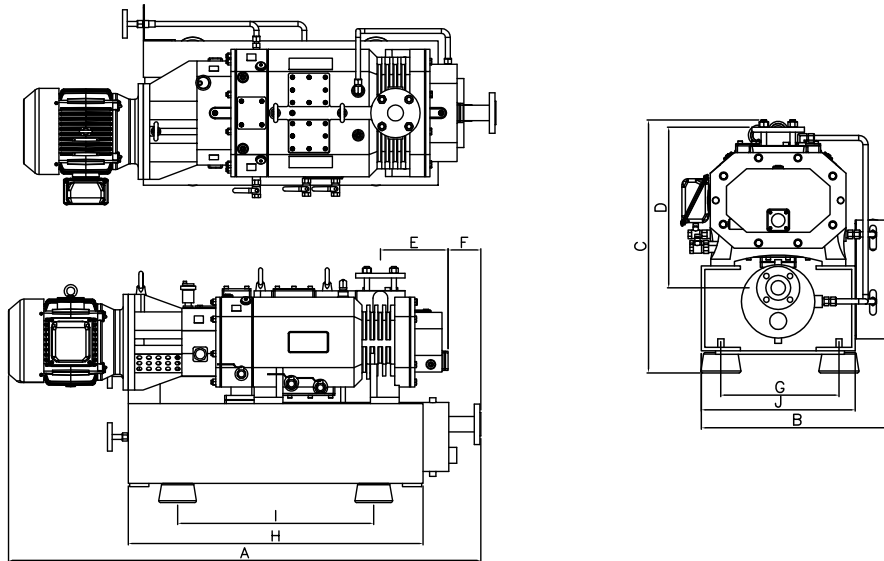

Model	A	B	C	D	E	F	G	H	I	J
MDP300B	1482	565	745	475	212	105	345	925	615	453
MDP400B	1640	576	757	486	230	50	350	990	680	465
MDP600B	1746	576	760	510	235	78	350	1174	865	465
MDP800B	1870	612	855	566	864	110	370	1245	935	500

## APPLICATIONS

포장작업 공정 : 식품진공포장, MAP포장, 성형포장, 블리스터 포장, 튜브포장기 포일운송  
 가스제거 공정 : 식품생산, 플라스틱 압출, 진공주조, 진공함침, 열처리, 표면코팅, 진공용기  
 코팅작업 공정 : 금속, 플라스틱, 유리의 코팅 - 라미네이팅 공정 : 태양전지 제품, LCD, 휴대폰 디스플레이  
 건조작업 공정 : 식품의 동결건조, 분유생산, 슬러지건조, 목재건조, 합성수지 입자 건조  
 증류작업 공정 : 원유증류, 제약 및 화학분야의 진공 증류  
 이송작업 공정 : 병원의 흡입이송, 식품의 이송, 플라스틱 제품의 이송, 수분함유 폐기물 이송  
 고정작업 공정 : 금속, 비금속, 플라스틱 흡착 고정

Packing : food vacuum, MAP, forming, blister and tube packing

Degassing : food industry, plastic injection press, vacuum casting, vacuum impregnation, heat treatment, surface coating

Coating : coating at metal, plastic, glass, etc

Lamination : solar battery products, LCD, mobile phone display

Drying : food freeze-drying, milk powder production, sludge drying, wood drying, synthetic resin particle drying

Distillation : oil distillation, vacuum distillation in chemical and pharmaceutical industry

Transfer : inhale transfer in hospital, food transfer, plastic transfer, water vapour containing waste transfer

Fix : suction mounting

**MECHANICAL BOOSTER PUMP**

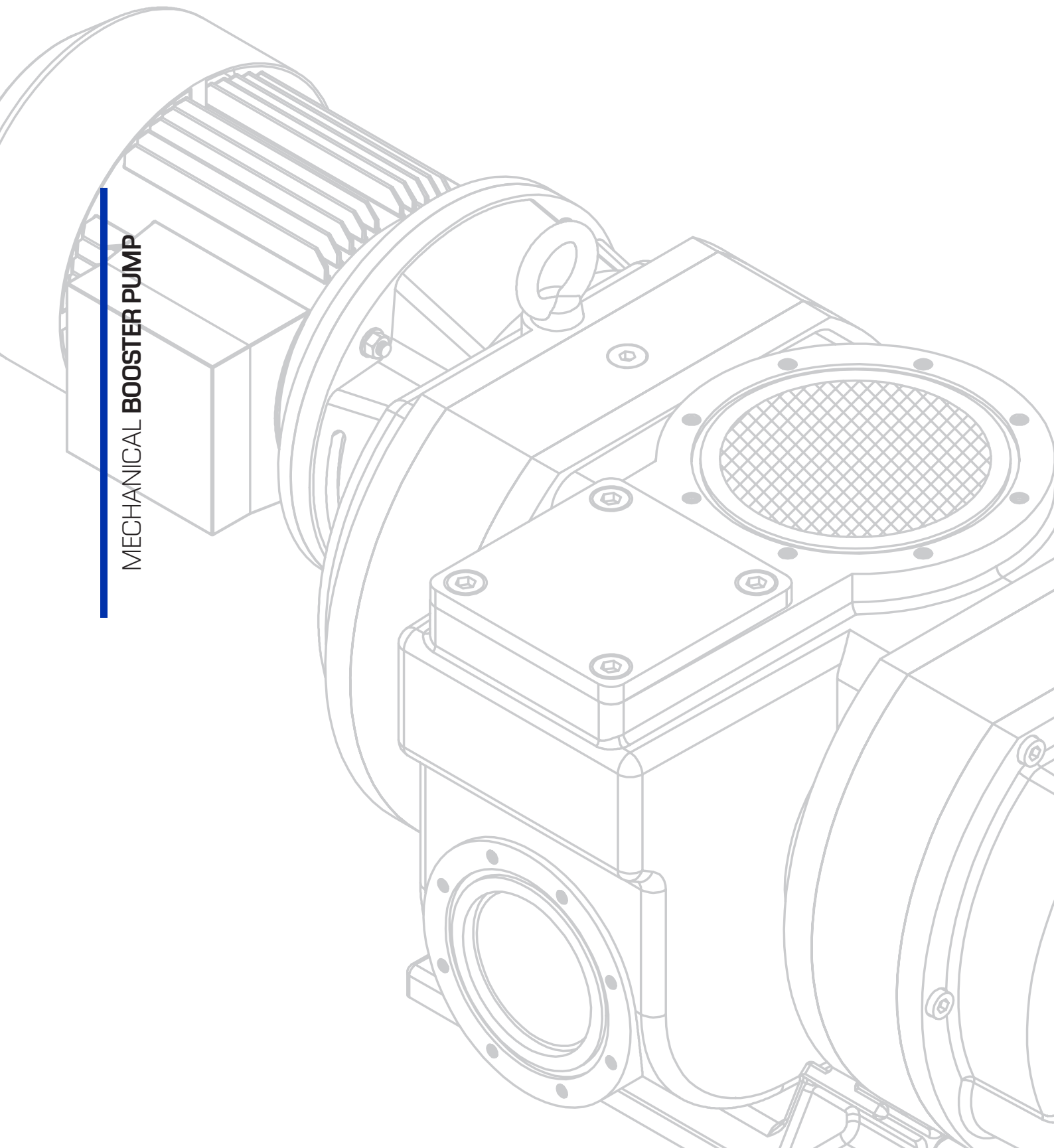

Mechanical  
**Booster Pump**

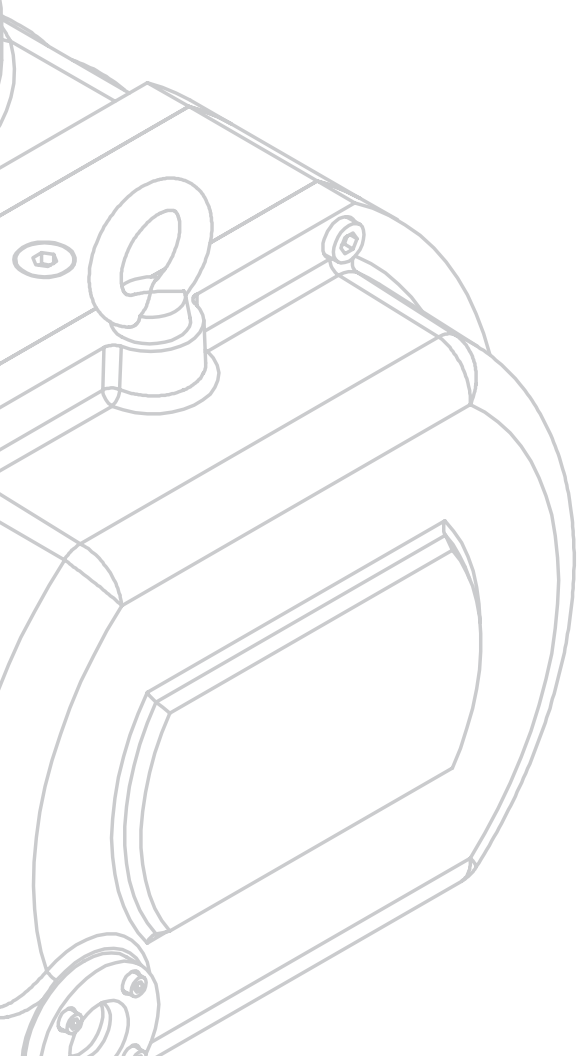

**FRU**

– FRU 180 / 360 / 720  
1440 / 2880 / 5800

# MECHANICAL BOOSTER PUMP

## FRU

---

- FRU 180 / 360 / 720  
1440 / 2880 / 5800



## DETAIL

---



## EXTERNAL PUMP SKETCH

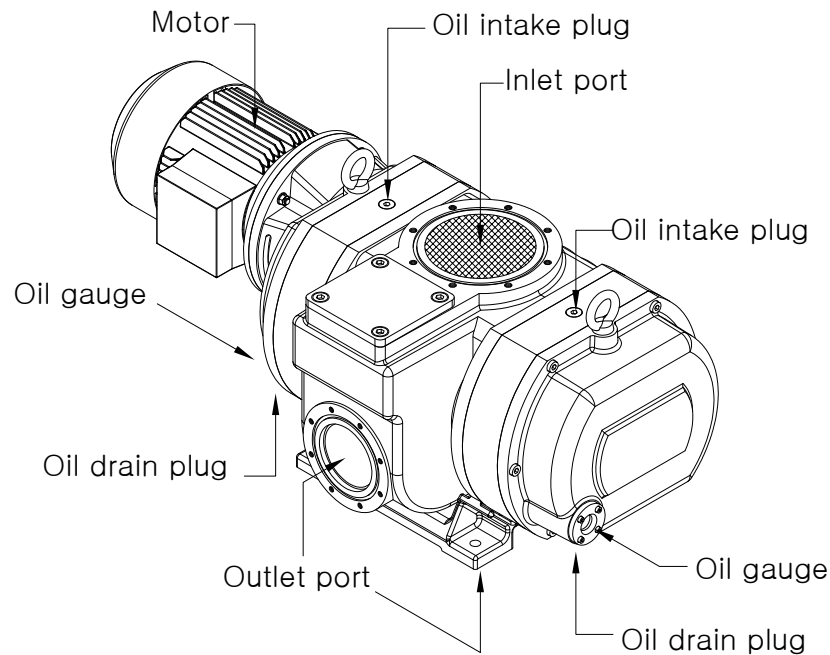

## DESIGN FEATURE

1. 대기압 작동형 펌프로 작업시간을 단축하여 에너지 소비를 감소
2. 안정된 펌프성능을 유지하며 모든 진공 작업 공정에 사용가능
3. 공랭식냉각
4. 배기구를 수평, 수직으로 사용하는 구조로 후단펌프와 배관연결이 용이
5. ISO 국제 규격에 따른 흡입구, 배기구 플랜지사용.
6. 저소음, 저진동
7. 간단한 유지보수 및 수리의 용이성

1. Saved energy consumption by reduced operating time by inhaling from ambient pressure.
2. Steady and excellent performance and applicable in all vacuum applications.
3. Air-cooling system.
4. The pump have two outlet port, vertical and horizontal, to enable convenient piping with backing pump.
5. ISO flange is used for inlet and out port.
6. Low vibration level, low noise level.
7. Easy maintenance and repairing.



## TECHNICAL DATA

DESCRIPTION		UNIT	FRU180	FRU360	FRU720	FRU1440	FRU2880	FRU5800	
Displacement Speed	50Hz	L/min	2500	5000	10000	20000	40000	80000	
	60Hz		3000	6000	12000	24000	48000	96000	
Ultimate pressure with 2 stage backing pump		Torr	$5 \times 10^{-5}$						
Inlet pressure(Max.continuous)		Torr	760						
Inlet port		ISO	63	63	100	160	160	250	
Outlet port		ISO	63	63	100	100	160	200	
Motor	Power		kW	0.75	1.1	2.2	3.7	7.5	15
	Voltage	50Hz	V	220/380/420					
		60Hz		220/380/440					
Rotational speed of pump		50Hz	R.P.M	3000					
		60Hz		3600					
Oil Filling		L	0.6	0.6	1.6	2.4	4.7	7.0	
Weight		Kg	87	105	191	296	494	884	

## PUMPING SPEED CURVE

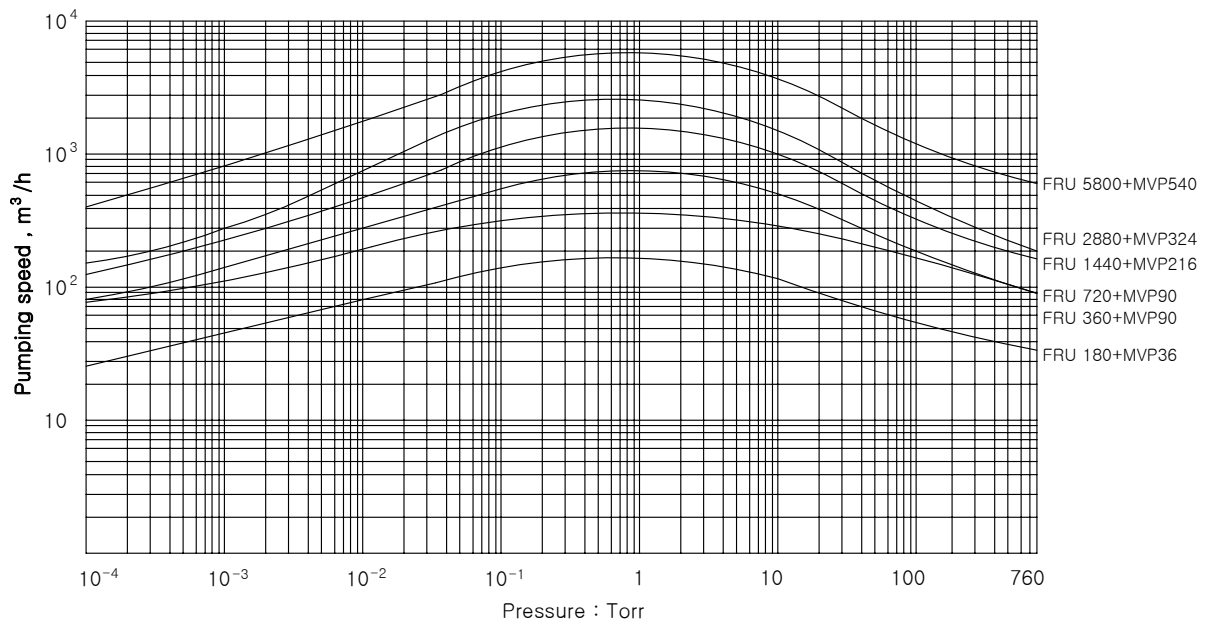

## OUTSIDE DIMENSION

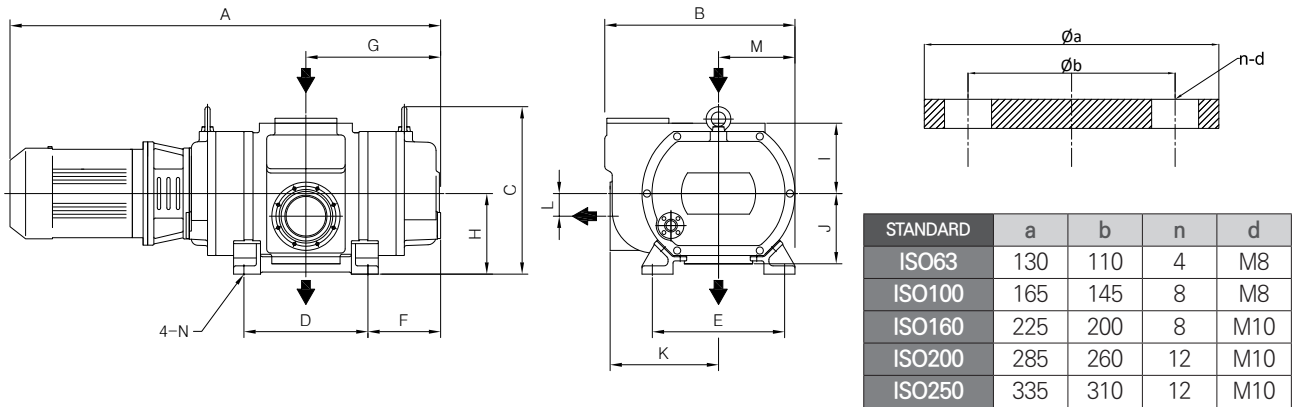

Model	A	B	C	D	E	F	G	H	I	J	K	L	M	N
FRU180	687	287	299	188	210	117	211	145	120	120			127	Ø13
FRU360	797	287	299	298	210	117	266	145	12	120			127	Ø13
FRU720	894	388	352	260	27	154	284	170	145	145	218	40	158	Ø13
FRU1440	1040	460	405	300	320	173	323	195	170	170	262	55	185	Ø15
FRU2880	1172	575	502	350	410	187	362	245	215	215	325	65	235	Ø18
FRU5800	1483	680	592	480	480	190	430	285	215	255	388	90	278	Ø18

## APPLICATIONS

포장작업 공정 : 식품진공포장, MAP포장, 성형포장, 블리스터 포장, 튜브포장기 포일운송

가스제거 공정 : 식품생산, 플라스틱 압출, 진공주조, 진공함침, 열처리, 표면코팅, 진공용기

코팅작업 공정 : 금속, 플라스틱, 유리의 코팅 - 라미네이팅 공정 : 태양전지 제품, LCD, 휴대폰 디스플레이

건조작업 공정 : 식품의 동결건조, 분유생산, 슬러지건조, 목재건조, 합성수지 입자 건조

중류작업 공정 : 원유중류, 제약 및 화학분야의 진공 증류

이송작업 공정 : 병원의 흡입이송, 식품의 이송, 플라스틱 제품의 이송, 수분함유 폐기물 이송

고정작업 공정 : 금속, 비금속, 플라스틱 흡착 고정

Packing : food vacuum, MAP, forming, blister and tube packing

Degassing : food industry, plastic injection press, vacuum casting, vacuum impregnation, heat treatment, surface coating

Coating : coating at metal, plastic, glass, etc

Lamination : solar battery products, LCD, mobile phone display

Drying : food freeze-drying, milk powder production, sludge drying, wood drying, synthetic resin particle drying

Distillation : oil distillation, vacuum distillation in chemical and pharmaceutical industry

Transfer : inhale transfer in hospital, food transfer, plastic transfer, water vapour containing waste transfer

Fix : suction mounting

# Vacuum Accessories

We provide our customers with full range of accessories including oil mist filters, vacuum pump oil, and third party components. Almost all requirements of our customers could be satisfied and our technical team is ready to help for selection of correct parts. Meanwhile with our professional know-how, we help to analyze the operating cost of our customers.



## OIL MIST TRAP – TMF SERIES

**MODEL** TMF12  
**APPLIED TO** MVP6, MVP12

**MODEL** TMF36  
**APPLIED TO** MVP24, MVP36

**MODEL** TMF90  
**APPLIED TO** MVP60, MVP90



## INLET TRAP – WSL SERIES

**MODEL** WSL- 825  
**APPLIES TO** MVP6, MVP12, MVP24, MVP36, WATS0020~WATS0080

**MODEL** WSL- 849  
**APPLIES TO** MVP60, MVP90, 80, 120, WATS0130~0200

**MODEL** WSL- 851  
**APPLIES TO** MVP144~540, 180~324, WSSR-V SERIES, WATS SERIES



**OIL MIST TRAP – WSG SERIES**

**MODEL** WSG-848  
**APPLIES TO** MVP60, MVP90

**MODEL** WSG-850/860  
**APPLIES TO** MVP144,216  
 WSSR-V1,5K,2,5K

**MODEL** WSG-244/344  
**APPLIES TO** MVP324,432,540  
 WSSR-V4,8K,7,5K



**INLET TRAP ELEMENT**

**MODEL** WSL ELEMENT  
**APPLIES TO** WSL SERIES  
**MATERIAL** POLYESTER



**OIL MIST TRAP ELEMENT**

**MODEL** TMF ELEMENT  
**APPLIES TO** TMF SERIES

**MODEL** WSG ELEMENT  
**APPLIES TO** WSG SERIES



**OIL MIST TRAP ELEMENT**

**MODEL** WSO ELEMENT  
**APPLIES TO** WATS SERIES,  
 WSS B SERIES,  
 WST B SERIES

**VACUUM FITTING**



**CENTER-RING**

**SIZE** NW16 ~ NW50  
**MATERIAL** SUS304



**C-CLAMP**

**SIZE** NW16 ~ NW50  
**MATERIAL** ALUMINIUM



**KF BLANK**

**SIZE** NW16 ~ NW50  
**MATERIAL** SUS304



**KF TEE**

**SIZE** NW16 ~ NW50  
**MATERIAL** SUS304



### KF 4 WAY CROSS

**SIZE** NW16 ~ NW50  
**MATERIAL** SUS304



### KF-KF CONICAL REDUCER

**SIZE** NW16 ~ NW50  
**MATERIAL** SUS304



### KF Tube Adapter

**SIZE** NW16 ~ NW50  
**MATERIAL** SUS304



### KF HALF NIPPLE

**SIZE** NW16 ~ NW50  
**MATERIAL** SUS304  
**LENGTH** SHORT 20MM,  
LONG 50MM



### WELDED METAL BELLOWS

**SIZE** ISO, KF, JIS  
**MATERIAL** STAINLESS STEEL  
SUS304, SUS316



### SPARE KIT

**APPLIES TO** ALL PUMPS  
**MINOR REPAIR KIT,**  
**MAJOR REPAIR KIT**



### VACUUM OIL

**MODEL** WS100 (ISO46)  
**APPLIES TO** MVP, WST, WSSR-V SERIES

**MODEL** WS200 (ISO68)  
**APPLIES TO** MVP, WST, WSSR-V SERIES

**MODEL** WS300 (ISO100)  
**APPLIES TO** WATS, WSS-B SERIES

PUBLISHED BY WOOSUNG VACUUMPUMP CO.,LTD.  
<http://www.vacuumkorea.com>

주 소 경기도 김포시 양촌읍 황금로 258번길 14  
전 화 031.432.7324  
팩 스 031.498.7328  
E-mail [topwoosung@naver.com](mailto:topwoosung@naver.com)