

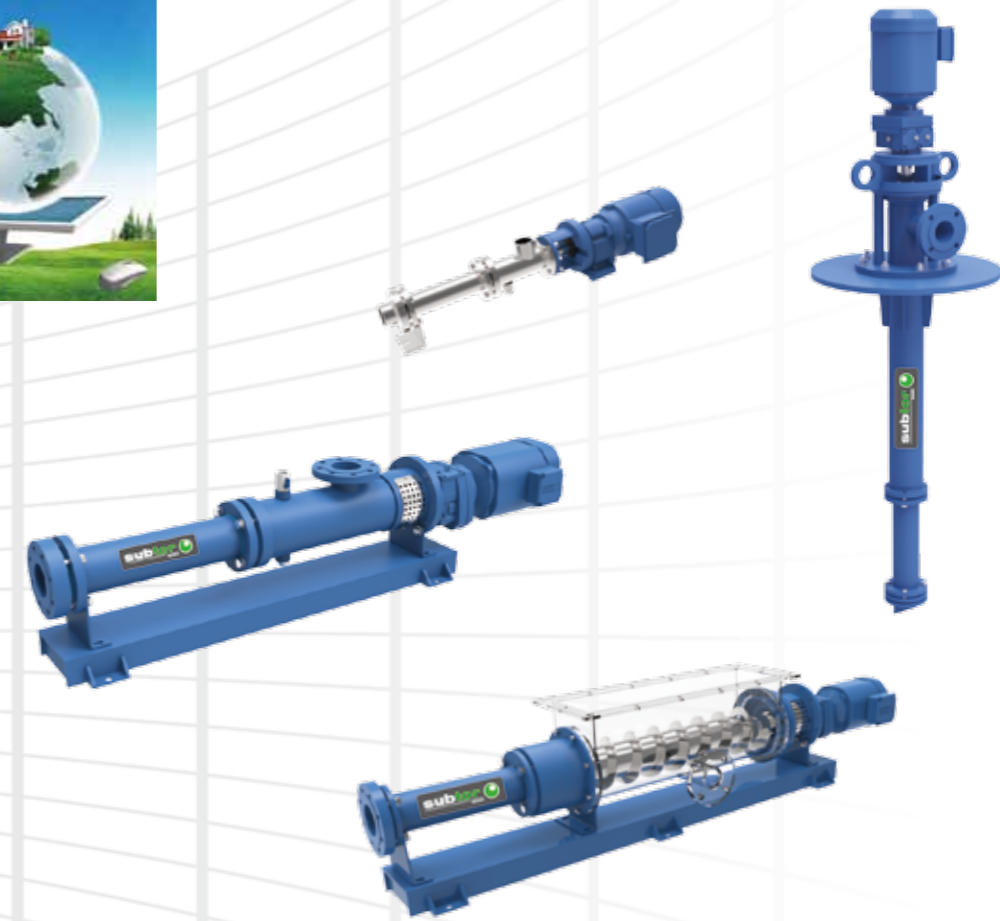

Subtor PC Pump in Water Treatment Industry

Green Mountain and Clean Water ----- Our Consistent Goal



High Performance German
Down hole and Conveying Technology

• **China Factory**

Weifang Subtor Rotating Precision Machinery Co.,ltd
Add: East side of No.2 Industry road,
Weifang, Shandong province, China
Tel: +86 536 5070802
+86 189 0636 9319
Fax: +86 536 5070760
Email: info@subtor.com.cn
Web: www.subtor.com.cn

• **ASEAN**

Subtor Asia Pacific
Add: Subtor Asia Pacific Pte Ltd,
7 Gambas Crescent, #08-38
Singapore 757087
Tel: +65 6465 5446
Email: info@subtor.com.sg

• **Germany Headquarter**

Add: Gewerbegebiet Salzhub 9
D-83737 Irschenberg Germany
Tel: +49 8031 8873 804
Fax: +49 8031 8873 805
Web: www.subtor.com

• **America**

Subtor America Inc.,S.A.Panama
Add: Plaza San Francisco, Office
#23, Boquete,Panama
Tel: +58 414 6127 358
+58 414 6138 777
Email: america@subtor.com
venezuela@subtor.com

• **Austria**

Subtor Austria
Add: Stadtplatz 24/7 A-4840
Vöcklabruck Austria
Tel: +43.7672-21063

Subtor PC Pump in Water Treatment Industry/Rev1.202012



Subtor website



WeChat official account



Factory in China

Company Profile

Weifang Subtor Rotating Precision Machinery Co.,Ltd.,a joint venture with Germany Subtor GmbH,is an international enterprise professional in research,design, production and sales of relative products based on moineau principle.

Beside having manufacturing plants and technical centers in Germany and China, we have sales offices and customer service centers in Central America and Asia Pacific region as well.we have agents and sales representatives in America, Russia, Kazakhstan, Kuwait, India and South America.

Key products: progressive cavity pump, macerator, downhole pc pump, power section of mud driller, stator core, the relevant spare parts and services.



Bridge Water Family

Advantage No.1

- Introduced German technology, leading level worldwide, German original core components such as stator rubber, universal joint rubber sleeve.
- Individual customization to meet various requirements of different applications.

Advantage No.2

• The rotor, one of the core parts, its size precision will directly affect the quality of product. To guarantee the reliable high quality,German professional automatic rotor process center-PS1000 is introduced.

The largest size specification and the highest precision of the same scale equipment in Asia.

- The maximum process length 10,000 mm
- The maximum process diameter 300mm



Germany original PS 1000 Rotor Process Lathe

Advantage No.3

Quality Assurance

- ISO 9001 Quality Management System
- ISO 14001 Environment Management System
- ISO 45001 Occupational health and safety Management System



Other Advantages

- More than 20 years' experience and expertise.
- The mature and unique rubber formula and technology.
- Consistent updated technology.
- So many application projects both at home and abroad to prove the reliable high quality.
- Professional after-sales engineers, more efficient service.



Our Goals

- First-class quality is priority
- Always focus on safety operation
- Satisfactory professional service
- Customers' maximum benefit

Working Principle and Structure of PC Pump

The conveying process of PC pump depends on the sealed chambers which are formed by the interference fit between the eccentric rotation of rotor and the stationary stator. When the rotor is eccentric rotating within the stator, the internal sealed chambers of PC pump are moved along the axial direction from pump's entrance to outlet, thus the fluid in the chambers can be continuously conveyed.



Key Characteristics of PC Pump

- High efficiency, volumetric efficiency up to 95%, mechanical efficiency 65 -85%, saving energy.
- Pulsation free, no shear, no extrusion, no damage to medium's physical property.
- Flow rate is directly proportional to rotating speed, which can be used for metering, dosing accuracy tolerance $\pm 1\%$.
- Low vibration, low noise, continuous conveyance.
- Suitable for medium with temperature ranges from -20°C to $+180^{\circ}\text{C}$.
- Suitable for medium with high solid content up to 65%.
- Suitable for medium with viscosity up to 1,000,000 cP.
- Suitable for medium mixed with fiber, grass and gas.
- Suitable for the shear-sensitive or centrifugal force-sensitive polymer medium.
- Suitable for the multiphase medium mixed with gas, solid and liquid.
- Excellent self-priming capacity, suction height can be 3-5meter for water column.
- Simple structure, easy to maintain, without special tools.



Pumped Medium Range

For the special structure and working principle, PC pump is the most suitable for the conveyance of various medium with solid particle, fiber, gas, viscous, corrosive, shear-sensitive and at different temperature.

Subtor pc pump have been widely used in municipal water treat industry, and the sewage/dewatered mud cake further treatment including but not limited to the industry of paper and pulp, steel, power generation, petroleum, chemistry, biogas, marine, food and beverage, pharmaceutical, cosmetic and so on.

Municipal Water Treatment Industry

To convey sewage, slurry, mud cake, additives such as: PAM, PAC, sodium diacetate.



Paper and Pulp Industry

To convey sewage, slurry, mud cake, various additives.



Power Generation Plant

To convey slurry, mud cake, the sewage from desulphurization and denitration process.



Steel Plant

To convey various waste liquid, such as: cutting fluid, waste oil, waste diesel and sewage.



Petrochemical Plant

To convey various waste liquid and sewage from various process procedures.



Other Industry

Sewage transportation in electroplate plant, condiment plant and cosmetic plant and so on.

Stator Raw Material

Stator rubber is directly imported from Germany to guarantee high quality. High acrylonitrile content NBR rubber is selected for the outstanding properties of anti-abrasion, oil resistance, anti-corrosion, aging-bearing, high tensile strength.



Rubber Injection Machine

To be suitable for various applications, EPDM rubber, FKM rubber, HNBR rubber, Silicone rubber and PTFE stator are all available for the different requirements of corrosion, abrasion, temperature.



Rubber Compounding Process

PTFE stator is strongly recommended for the special application of acid and alkaline strong corrosion, high chloride ion content, and high temperature. The PTFE stator is directly imported from Germany with original package, excellent comprehensive performance, withstanding strong corrosion of acid and alkali, high temperature resistance (highest 230°C and lowest -180°C). Very suitable to transfer the fluid of hydrochloric acid and medium with high chloride ion content.



Germany Original PTFE Stator

Silicon rubber stator is also available and has been widely used in chemical, paper making, food and pharmaceutical industry. Excellent performance for both high and low temperature endurance (from -55 °C to 150 °C), anti-corrosion of acid and alkali, aging-bearing, none toxic and no special odor.



Silicon Rubber Stator

Rotor Raw Material

Various raw material are available such as carbon steel, SS304, SS316, SS316L, duplex steel, titanium alloy based on the application and medium in water treatment industry.



Rotor surface with chrome plated treatment



Rotor being mirror-grade polished



Rotor with vacuum quenching treatment



Rotor with spray welding treatment

The relationship between medium's temperature and interference size of stator and rotor

The cooperative size between stator and rotor is little interference fit to ensure air-tightness and high transportation efficiency. The rotor's diameter is different based on the medium's actual temperature.

The relationship between rotor's temperature grade and medium's actual temperature.

Rotor temperature grade and medium temperature table						
Medium Temperature	normal room temperature	31< to <50	51< to <70	71< to <90	91< to <110	111< to <130
Rotor Size Grade	C2	C4	C6	C8	C10	C12

The medium's temperature provided by customer must be objective and correct so as to choose the rotor's optimum size and proper stator elastomer for better transportation performance.



Shaft Seal

• Packing Seal

Packing seal is divided into two types: one with water flushing and the other without water flushing.

The sealed section of connecting shaft is treated with CrC thermal spray welding technology, with the HRC 63-66°, excellent abrasion resistant property.

Small leakage of packing seal must be permitted to lubricate the connecting shaft and take away the heat caused by friction to protect connecting shaft and stuffing from dry running.



Connecting shaft with spray welding treatment

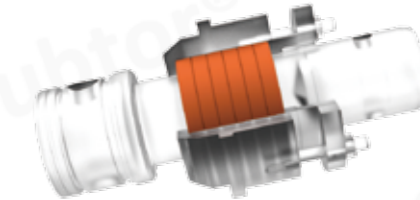

Packing seal installation method

• Mechanical Seal

Mechanical seal is divided into single mechanical seal and double mechanical seal.

Various form and material are available based on different application and medium.



• Rotating Mechanical Seal

Two types are for choice: cartridge rotating mechanical seal and common rotating mechanical seal.

Subtor patented design, excellent usage performance, easy installation, widely used in sewage and kitchen waste treatment industry.

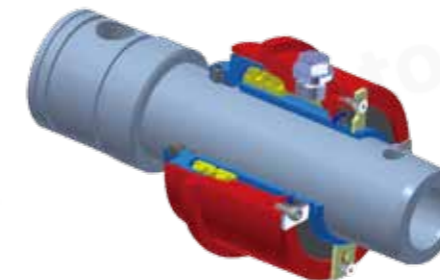

Cartridge rotating mechanical seal



Common rotating mechanical seal

Pin Type/ Pin with Bushes Type Universal Joint

Simple design, easy maintenance, inner and outer layers of rubber sleeve, more reliable and safe operation. Pins are made of high speed steel with quenching treatment, excellent performance of highly tensile strength, good flexibility, anti-abrasion, longer service life. Widely used in small and medium model pumps.

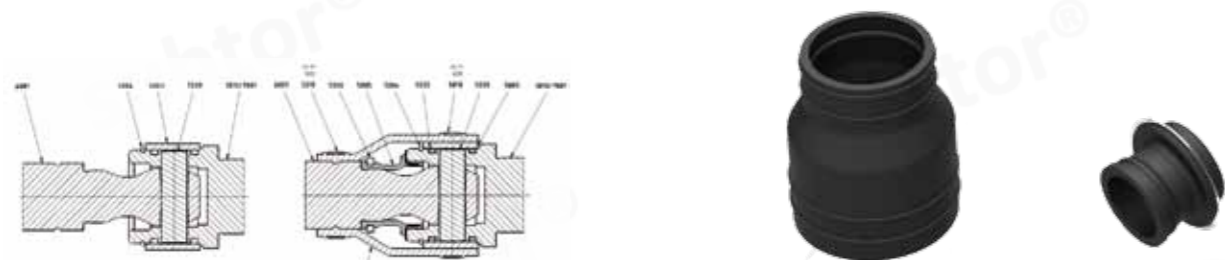

Internal and external universal joint rubber sleeve

Cardan Type Universal Joint

For the multi-stages progressive cavity pumps with high flow rate and high differential pressure, the specially designed cardan universal joint is strongly recommended, with the outstanding property of reliable and safe operation, internal and external two layers rubber sleeve, withstand the torque and axial force 2.5 times more than the required, longer service life, very satisfactory application performance, widely and successfully used in the pumps model above VD120.

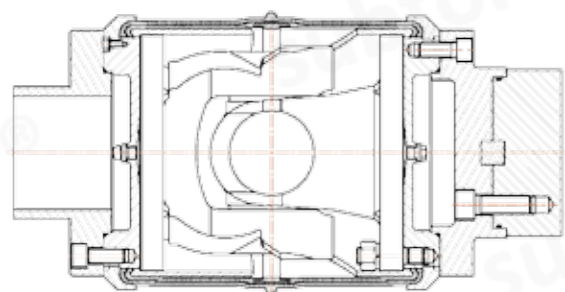

The sectional drawing of cardan joint



Cardan universal joint and coupling rod

Special Designed Features

- **Water Injection Valve**

Special designed ball valve on the pump suction housing, prime the pump to avoid dry run by adding water or other liquid before start pump.

Also exhaust function, open the valve before start to accelerate the fluid much easily into the pump housing.

- **Drainage Plug**

Make it much easier to clean the pump housing.

- **Lantern Protective Cover**

Special designed protective cover or acrylic board installed on pump lantern, much easier to observe the internal working condition and prevent fiber, hair, plastic bag into the lantern, much safer running, easy to install and disassemble.

- **Inspection Window (at option)**

Inspection windows are available according to customer's requirement for more convenient to check the universal joint condition for large model pump. Just to loosen the nuts and no necessary to disassemble the pump, save your valuable time.

- **None Thrust Bolt Structure**

Flange connection instead of thrust bolt makes much easier and time-saving to install and disassemble pump. Convenient to maintain. Heating jacket, cooling jacket and other accessories are more convenient to install and repair.

- **Stator Protection Device from Dry Running**

It's used to measure the rubber's temperature, and the temperature controller will give alarm or stop automatically when the actual temperature exceeds the pre-set value.

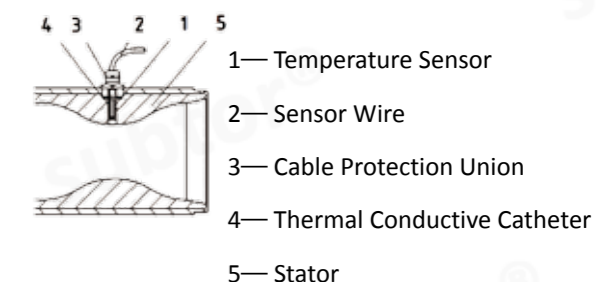

5— Stator



Mechanical Seal Flushing System

Mechanical seal flushing system is chosen based on different application and medium condition, according to API 682 standard, so as to prolong the mechanical seal service life and assure the pump's reliable and safe operation. Widely used flushing system: PLAN 53A, PLAN 53B, PLAN 31, PLAN 54 and so on.

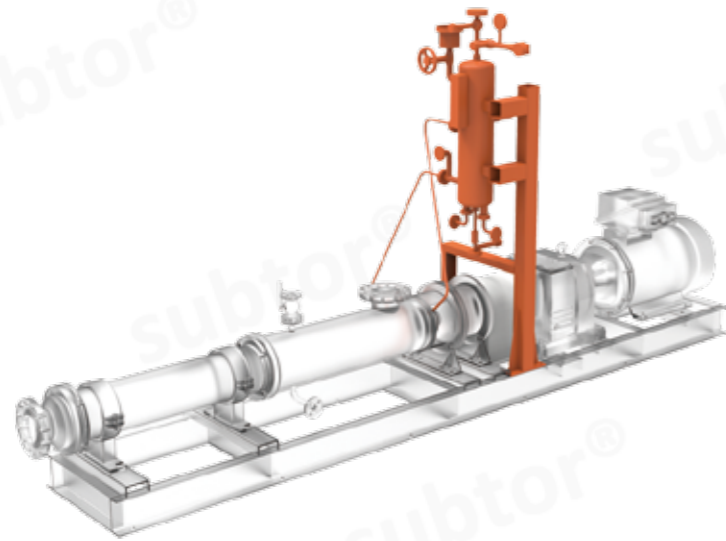

Sketch drawing of mechanical seal flushing system



Geared Reducer and Motor

- Geared Reducer

To ensure the reliable operation, the geared reducer of German SEW brand or NORD brand or Chinese JIE brand are strongly recommended. Outstanding advantages of stable reliable running, lower noise, lower vibration, safe operation and well-known high quality products.



- Explosion-proof Motor

ABB brand explosion-proof motor is usually used as the leading drive solutions provider worldwide. Also NANYANG, DAZHONG, or XI'ANDA explosion-proof motors are also available for choice.



- Other Accessories

To ensure the pump's high quality, imported SKF or FAG bearing, German original UKS framework oil seal are adopted.



SKF



UKS

Widely Used PC Pump Types in Water Treatment Industry

MM Class - Metering Pump

Compact structure, accurate dosing, no pulsation, capacity being proportional to rotating speed, dosing accuracy tolerance $\pm 1\%$, widely used to pump PAM, PAC and other additives.



S Class - Direct Coupled

Compact structure, easy to maintain, lower initial investment, widely used to pump sewage with solid content no more than 10%.

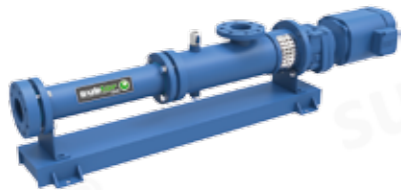

A Class - with Bearing Housing

Separated bearing housing, withstand higher axial force, be compatible with various drive devices, more suitable for higher differential pressure application.

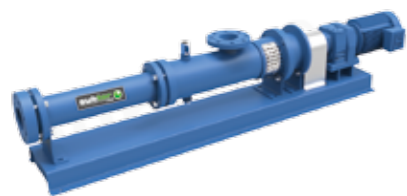

M0 Class - Inlet Larger Flange

The pump is specially designed with inlet larger flange and feeding screw blade to push the viscous medium into pump cavity, quite suitable for conveying the slurry with solid content below 12%.



M1 Class - Hopper Inlet

The pump is designed with small rectangular hopper, compatible with different size and shape inlet pipeline, and feeding screw blade, quite suitable for pumping the viscous fluid with solid content below 18%.

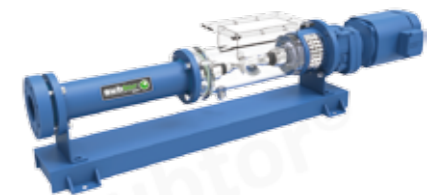

M2 Class - Hopper Inlet

Big rectangular hopper is designed as suction housing, very suitable for pumping the medium with high viscosity, high solid content and poor fluidity. Coupling rod is equipped with propulsion unit of screw conveyor, effectively to push the fluid into stator cavity and prevent accumulation at the entrance. Very suitable for the transportation of highly viscous fluid such as dewatered sludge cake with solid content 18%-30%. The size of rectangular hopper can be customized according to different installation condition.

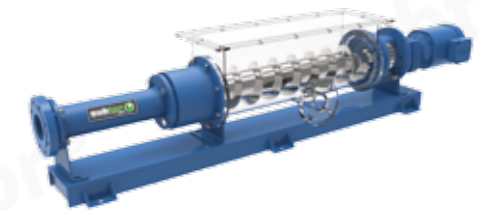

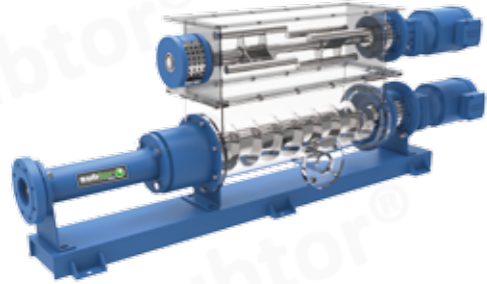

M3 Class - Hopper Pump with Bridge Breaker

On the basis of M2 class hopper pump, an additional bridge breaker device is added to help the highly viscous medium entrance into suction housing and avoid bridging phenomenon. Suitable for transportation mud cake with solid content 30%-45%.



M5 Class - Prolonged Hopper Pump

Suction hopper and extrusion housing are prolonged for better transportation the mediums with poor fluidity and easy dehydration, solid content 10%-18%.

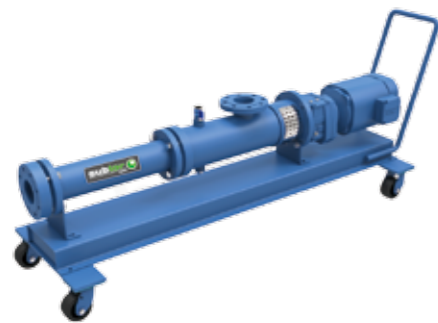

Vehicle Mounted Pump

By mounting Subtor standard pump on a trolley with wheels and handle, move the pump to where it is needed. Convenient to operate.

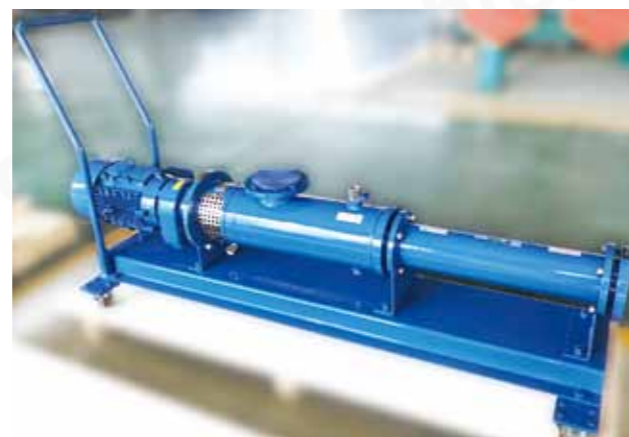
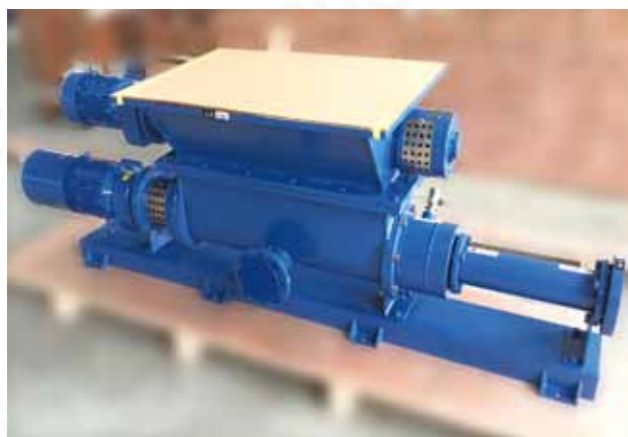

OU Class - Vertical Installation Pump

Vertically mounted, the design is used in sump pits and tanks containing high solid content and heavy medium. Pump body length varies with immersion depth. Alternative for installation with space limitation.

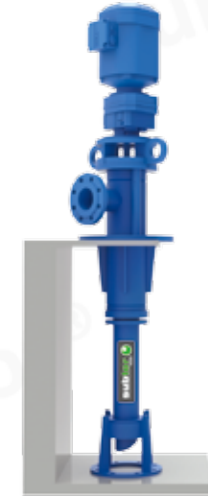

Macerator

Subtor macerator is mounted before the pump, used to cut up the blocky soft material and fibrous material in the medium; precipitate and collect the heavy solid to protect the pump from blockage or damage.



Subtor PC Pump Application Projects



Municipal Water Treatment Industry

During the municipal waste water treatment procedures, Subtor pc pump are widely used to transfer sewage, slurry, additives and dewatered mud cake.

Sewage Treatment Procedures

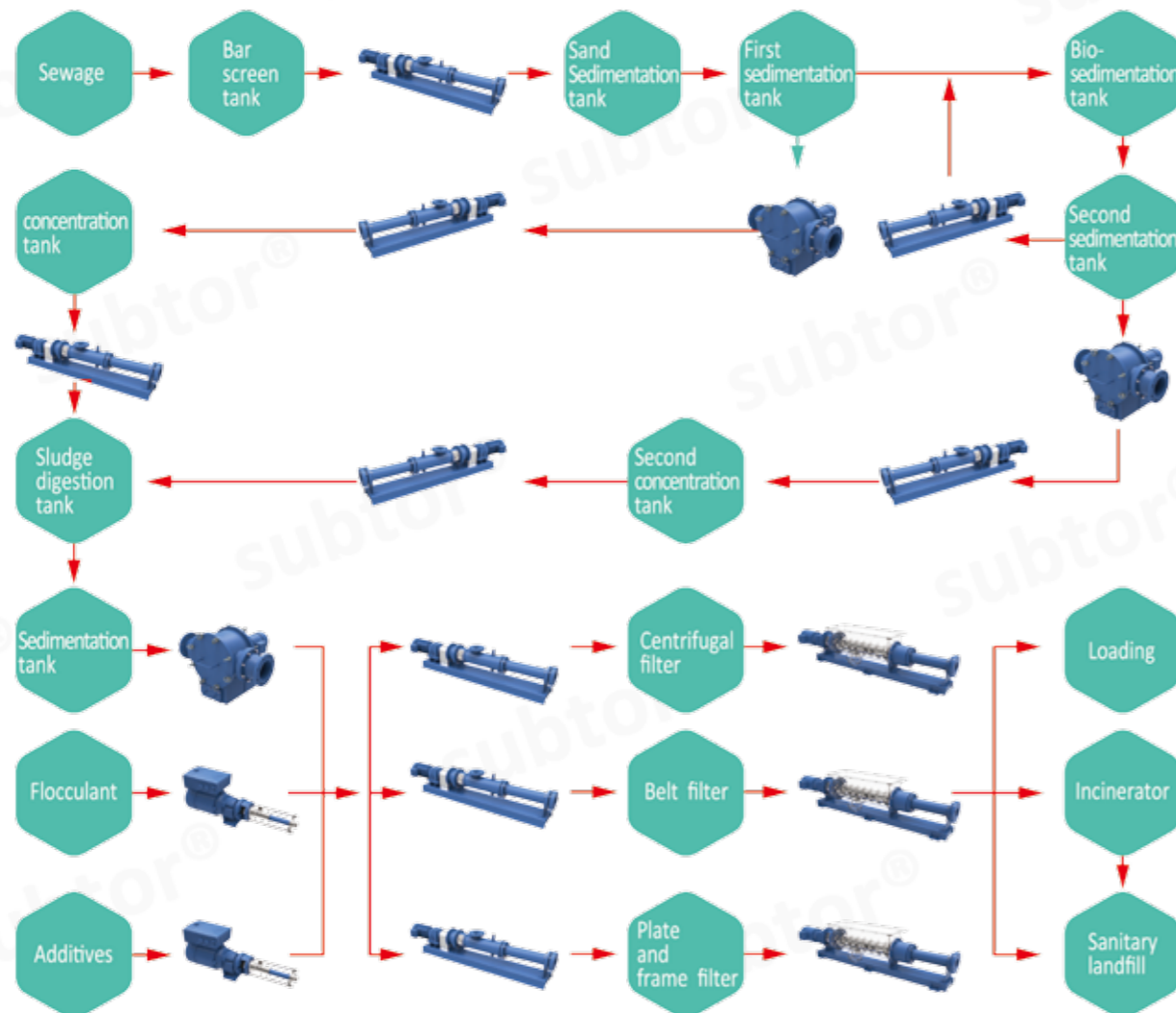

Subtor pc pump are used to accurately dose various additives, such as, PAM, PAC, sodium diacetate.



PAM accurate dosing pump



Additive injection pump

Direct-coupled S class pc pump are usually used to supply sludge (solid content: 1%-10%) to various filters, included but not limited to plate and frame filter, belt filter and centrifugal filter. Macerator is alternative installed before the pump based on the sewage condition for better pumping performance.



PC pump to transfer Sewage solid content 1-5%



Macerator Installed before pump

Subtor M2 class (open throat type)hopper pc pump is successfully used to efficiently convey the dewatered mud cake, solid content up to 45%.So many application projects, very satisfactory pumping performance.



Dewatered mud cake solid content 25%



M2 class hopper pump to transfer mud cake 18%-20% solid content



Open throat hopper pump to transfer mud cake 20-25% solid content

Subtor PC Pump in Paper and Pulp Industry



Paper and pulp industry is vey likely to cause environment pollution,if the massive sewage is not properly treated. The waste water main comes from the pulping and paper making procedures.



Subtor pc pump have been widely used to transfer this type of waste water, the rubber elastomer and metal parts are selected based on the pumped fluid' s components to ensure the reliable and durable operation.



Subtor PC Pump in Power Generation Industry



These years more and more power generation plants are newly built and more strict environment protection laws and regulations come into effect, which requires the higher standard in the qualified fume exhaust. The waste water, oily water, ashy water and desulfurization sewage mainly come from the procedures of desulphurization and denitration, rather complicated chemical and physical components.

These sewage, sludge are efficiently pumped by Subtor customized pc pump. All the rubber and metal parts are chosen according to the fluid's various components, such as PH value, solid content, chloride ion concentration.



Direct coupled pc pump are mainly used to convey the sludge with solid content 1%-10%.



The open throat hopper pc pump with reinforced screw conveyor is equipped to transfer the dewatered mud cake (solid content 15%-30%) to the incinerator for non-harmful process.



Subtor PC Pump in Steel Plant



The sewage in the steel plant mainly comes from two sources: the one from the recycled cooling water system (desalted water, softened water, and brine), and the other from the production procedures. The sewage's components are rather complicated, containing suspended solid, emulsified oil, oil slick, nitrite, ferrite, chloride ion, sulfide and so on.

The pump's metal parts and rubber parts are specially selected based on the sewage components to ensure the satisfactory performance.



Subtor PC Pump in Chemical Plant



The sewage in the chemical plant is mainly from the waste water in production procedures, cooling water, fume purified water and equipment wash water.

To meet the more and more strict requirements on environment protection, there are one-stop mature pumping solutions to convey the dangerous or poisonous chemicals to the storage tank instead of manual operation. More reliable and safe various chemicals high efficient transportation solutions.



Subtor vertical pc pump used for chemical sewage transportation



Chemical slurry continuous transportation

Subtor PC Pump In Other Industries



Green mountain and clean water---Our consistent goal!



There are also so many successful application projects in the sludge transportation of electroplate plant, condiment plant, cosmetic plant and so on.



Subtor sludge conveyance pc pump

Spare Parts

Common used wear parts are kept in stock; aimed to deliver to the client soonest when needed

- Rotor, Stator
- Connecting shaft, universal joint and coupling rod
- Universal joint internal and external rubber sleeve, framework oil seal and mechanical seal
- Other spare parts: round pin, spacer sleeve, long and short sleeve, clamp spring and so on.



After-Sales Service

Subtor professional after-sales service engineers are ready to serve you 24/7.

- On site training and guidance.
- Help and guide customers to solve the problems as soon as possible.
- Commissioning, maintenance and repair at site.
- Technical consultation and spare parts purchase suggestion.



Weifang International Kite Festival



Mutual Benefit



Weifang Aerial View

Welcome to Visit Subtor.