

MODULAR BREATHER VALVES PIPEAWAY

THE BEST SOLUTION FOR YOUR SAFETY

The breather valves pipeaway are safety devices developed to prevent un-allowable high and low pressure on vessels and process systems; the MODULAR valve design created by INNOVA provide the best solution to achieve flow performance, high tightness but with a compact and light design.

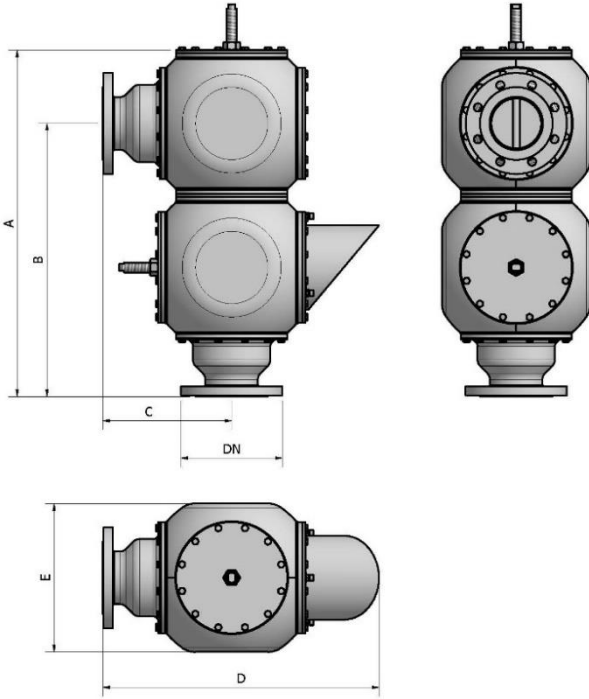

TECHNICAL DATA STANDARD PRODUCT

Settings:

Pressure: +2,0 mbarg up to +100 mbarg

+20 mmH2O up to +1000 mmH2O

Vacuum: -2,0 mbarg up to -100 mbarg

-20 mmH2O up to -1000 mmH2O

Operating temperature:

-29 °C up to +140 °C continue

(+210 °C Max working Peak)

-20,2 °F up to +284 °F continue

(+410 °F Max working Peak)

if you need non-standard calibrations or temperatures, we will try in every way to satisfy your request!

DN	A	B	C	D	E
25	372	295	145	289	140
50	473	343,5	178,5	376	192
80	627	493	231	502	265
100	755	595	281	602	323
150	989	776,5	359,5	804	442
200	1142	894	406	942	519
250	1359	1059	469	1117	623
300	1487	1161,5	520,5	1239	684

All measurements are expressed in mm (international metric system S.I.), the dimensions may vary for different reasons, for greater dimensional accuracy ask for the detailed drawing of the selected product.

MATERIAL OF CONSTRUCTION

Housing	Seat/Pallet	Pallet seal	Weights	Gasket
Aluminium	316 Stainless	Viton	316 Stainless steel	Asbestos Free
Stainless steel		PTFE	PTFE	PTFE
Carbon steel		FEP teflon	ETFE coated	Other on request
Other exotic material		Metal to metal	HALAR coated	

TECHNOLOGY OF BREATHER VALVE PIPEAWAY

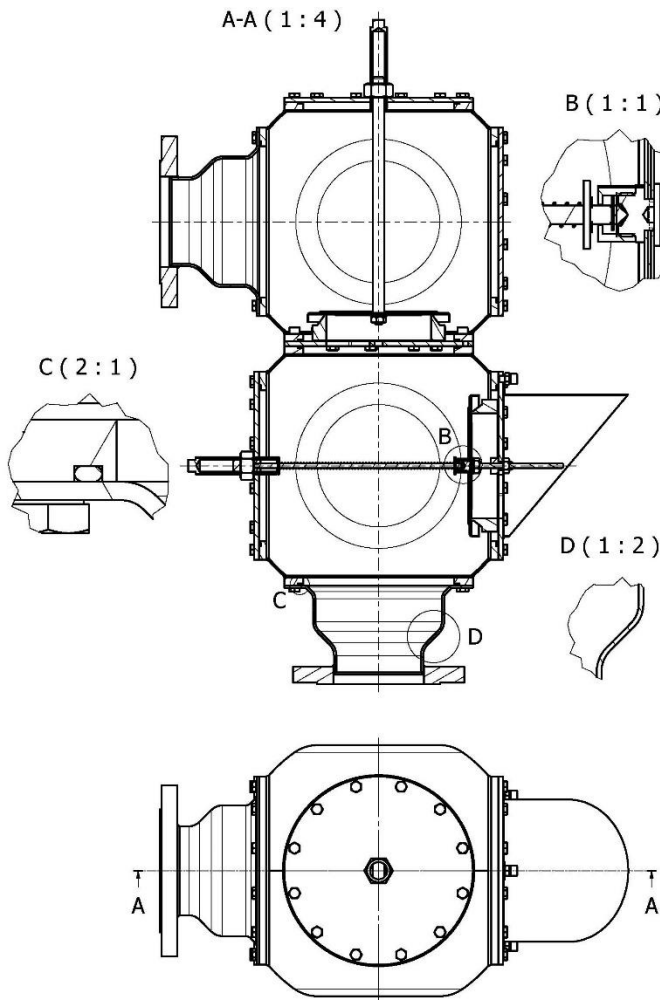

VIEW-B

The INNOVA "swivel joint" remove all parallelism defects between seat and pallet giving the best tightness solution. As result, both in case of weight or spring solution, the valve set is extremely accurate.

VIEW-C

O-rings are sealing each housing part giving the possibility to open and reclose the valve for inspection without need to replace them.

VIEW-D

The housing are fabricated from metal sheets providing the highest quality material with less Weight.

A NEW MANUFACTURING METHOD FOR THE HIGHEST QUALITY

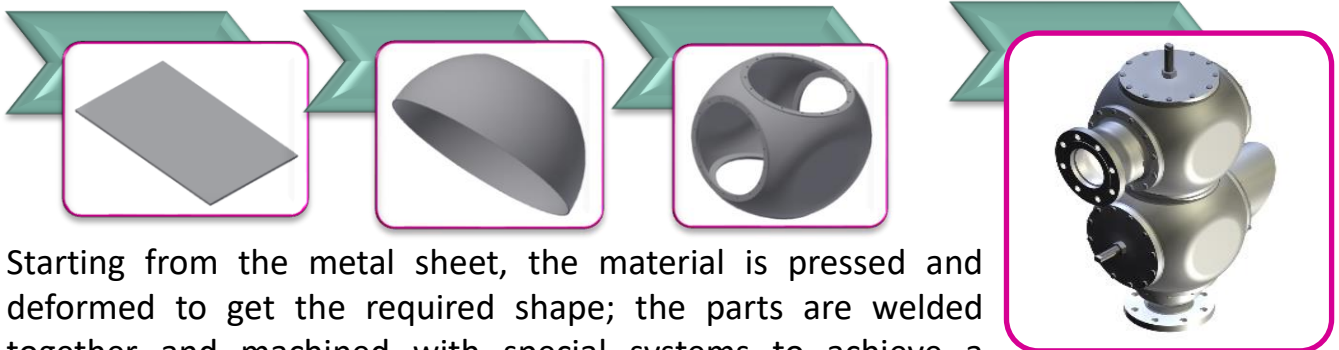

Starting from the metal sheet, the material is pressed and deformed to get the required shape; the parts are welded together and machined with special systems to achieve a perfect body; the result is a very light but high pressure resistance housing. The raw materials come from Europe and we are the only one providing a 100% Italian manufacturing.



HISTORY

INNOVA s.r.l. is an Italian metalworking company founded in October 2018.

The company was established to expand the SAIAPCK s.r.l. with the acquisition of the TANK PROTECTION DIVISION, branch of FNC.

SAIAPCK s.r.l., founded in 2012 with headquarters in MILAN (already a purchaser of the activity of BIMEC snc, founded in 1983), expert in precision machining and industrial automation. TANK PROTECTION DIVISION, specialist in the production of valves and systems for the protection of tanks and plants of low pressure.

INNOVA srl, despite being a young company, for its activity, it can immediately trust the professionalism, competence and experience of the staff of the two old companies and the reputation of their products on the market.

The fusion of the technological and mechanical know-how of SAIAPCK and the product and market know-how of TANK PROTECTION DIVISION has resulted in a perfect combination for worldwide development.

PRODUCTS

Currently the company is able to provide processing and assembly services for third parties through the OMAW division as well as propos-

als and solutions for industrial automation; the FNC VALVES division manufactures innovative products for the safety of storage facilities such as breather valves, flame arresters and a wide range of accessories for tanks and gas lines.

QUALITY

The company is ISO9001 and ATEX 2014/34 / UE certified with more than 250 type certifications according to ISO16852 in addition to the innumerable certifications related to the different applications (PED, DNV-GL, TR-CU, etc.).

MISSION

Providing real improvement proposals through innovation to satisfy customers by differentiating from commodities and low cost alternatives; expanding the business globally through rapid but structured growth, creating profit through process improvement and the satisfaction of all stakeholders with a particular focus on the quality of life of employees.

VISION

Excellence in service for automation and world leadership in the production of safety devices for plants.

INNOVA SRL

VIA ENRICO FERMI 4, 20080 ZIBIDO SAN GIACOMO (MI) - VAT: IT 07599570962

SALES@INNOVA-ITA.IT – WWW.INNOVA-ITA.IT